

Nova Scotia Greenhouse Pest Control Training Manual

2nd Edition
2006

Notice

This manual is provided for information only. Users of this manual rely on the contents of this manual at their own risk. This manual is not intended to be a representation of the current law on the subject of pesticide use. Users of this manual should always check with the appropriate authorities in their area to ensure Users are conducting their activities in a proper manner and in accordance with the laws of their jurisdiction. The Government of Nova Scotia, as represented by the Department of Environment and Labour, is in no way responsible for the activities of Users of this manual.

Acknowledgements

The Government of Nova Scotia wishes to thank Bev MacPhail for review and comments on the first edition and Saskatchewan Institute of Applied Science and Technology for the material in chapters 1 and 2 which has been adapted, with permission, from the Saskatchewan Pesticide Applicator - PEST 170 Greenhouse Manual.

The information in Chapter 3 on biological and reduced risk greenhouse pesticides was extracted from material produced by Kelvin Lynch, IPM Specialist, NB Department of Agriculture Fisheries and Aquaculture and published on line at http://www.gnb.ca/0171/40/bulletin_newsletter2005.pdf

Acknowledgements for the First Edition (1996)

The New Brunswick Department of the Environment and the Nova Scotia Department of the Environment would like to acknowledge the contribution of the Greenhouse Growers Association of Nova Scotia, Ridgetown College of Agricultural Technology and the Nova Scotia Department of Agriculture and Marketing.

The Greenhouse Growers Association Of Nova Scotia Pesticide Safety Manual was compiled and edited by Bev MacPhail P.Ag. and Brian Toms P.Ag. Plant Industry Branch NSDAM, January 1996.

Introduction

Greenhouse Pest control refers to the control of pests inside or on areas immediately surrounding a greenhouse during the storage, display or production of an agricultural crop including vegetables, ornamental trees, mushrooms and forest tree seedlings. A greenhouse operator must be able to identify, and know the basic life history, habitat and damage of greenhouse pests. From this information, the applicator must be able to determine a method of control, and if that method of control involves the use of pesticides, the applicator must ensure that pesticides are used safely and effectively.

This manual, the Nova Scotia Greenhouse Pest Control Training Manual, in conjunction with the Applicator Core Training Manual, contains the minimum amount of information that all greenhouse operators must know in order to become a certified pesticide applicator.

The Applicator Core Training Manual is divided into twelve sections covering such background information as legislation, pesticide characteristics, toxicity, and safety and other basic information that all applicators need to know.

The Nova Scotia Greenhouse Pest Control Training Manual focuses on information specific to pest control in greenhouses. Detailed information is presented on major pests as well as pest control methods used by greenhouse operators. Applicators wishing to obtain a Pesticide Applicator's Certificate for greenhouse pest control must be aware of the information contained within both manuals in order to pass an examination.

NOTE: Information pertaining to fumigation is not covered in this training manual. In Nova Scotia, the use of fumigant gasses is not covered by a Greenhouse Pesticide Applicator's Certification.

For additional information on pesticide certification, please contact:

Nova Scotia Department of Environment and Labour
P.O. Box 697
Halifax, N.S.
B3J 2T8
Tel: 902-424-5300

Copies of this manual are available on line at:
www.gov.ns.ca/enla/pests/applicator.asp

Table of Contents

SECTION 1: GREENHOUSE INSECT PESTS	1-1
SECTION 2: GREENHOUSE DISEASES	2-1
SECTION 3: USING BIOLOGICAL CONTROLS AND REDUCED RISK PESTICIDES	3-1
SECTION 4: GREENHOUSE PESTICIDE APPLICATION METHODS AND EQUIPMENT	4-1
SECTION 5: CALCULATIONS FOR PESTICIDE APPLICATION	5-1
SECTION 6: PESTICIDE APPLICATION RECORD KEEPING	

The Greenhouse Manual is to be used along with the Applicator Core Training Manual to prepare for the Nova Scotia Greenhouse Pesticide Applicators exam

SECTION 1 - GREENHOUSE INSECT PESTS

Insects damage plants in a variety of ways. They attack the seed, cut off young plants, chew foliage, suck the sap, bore and tunnel into the stems and branches and transmit diseases. Insects must be correctly identified before they can be properly controlled. In addition, the following information is needed to effectively control insects in the greenhouse:

- the insect's life cycle
- the insect's feeding habits (which plants, where on the plant, typical signs of damage)
- where the insects hide when it is not feeding

INSECT ANATOMY

An insect body has three main segments. These are: head, thorax and abdomen. The head bears a pair of compound eyes, one pair of antennae and the mouth parts. The thorax has three pairs of legs attached. **Insects only have six legs.** Wings, when present, are attached to the thorax. Located on each side of the thorax and abdomen are openings called **spiracles**. The insect breathes through these spiracles.

INSECT DAMAGE

Insects do the most damage when they are feeding on plants in the greenhouse. Understanding the feeding habits of the insect may help to apply effective control measures.

Chewing Insects and Their Damage

The mouthparts are adapted for biting off and chewing solid foods, such as leaves, wood, fabric or kernels of grain.

Damage caused:

1. Defoliators who strip and chew portions of foliage and stems.
Examples: caterpillars, cutworms, flea beetles
2. Leaf miners that bore into and tunnel between leaf layers.
Example: chrysanthemum leaf miner
3. Root feeders that feed on underground roots and plant portions.
Examples: fungus gnats, millipedes

Sucking Insects and Their Damage

Some insects pierce the surface of plants and suck liquids from the tissue below. They have a proboscis that looks like a slender tubular beak; inside this proboscis are several stylets which actually do the piercing and sucking.

Thrips are sucking insects that rasp the surface with the stylets until the sap flows out and then they retract the stylets and suck up the sap.

Damage caused:

1. Distorted plant growth such as curling, wilting and distortion of leaves, stems or fruit. Much of this distortion is due to minute amounts of toxins the insect releases into the tissue surrounding the area they have affected. In humans, this reaction causes the "bump" reaction to a bite. Examples: aphids, plant bugs, mealybugs.
2. Stippled effect on leaves due to small discoloured spots where an insect has sucked out the food value. The insect may only affect a few cells in each area. Examples: spider mite, white fly, mealybug, scale.
3. Burn symptoms due to toxic secretions given off by the insect. Example: leaf hopper injury called "hopper burn".

Insects with Sponging Mouthparts

These insects can only feed on sap outside the surface of the plant as they are unable to pierce the surface. They have an elongated lower lip or proboscis which encloses a salivary duct and a food channel. The salivary duct secretes saliva to dissolve the exposed liquid. The lower end of the proboscis is enlarged to act as a sponge which guides these fluids into the food channel where it is sucked up into the digestive tract.

Examples: houseflies and fruitflies.

Siphoning Insects

This insect has mouthparts consisting of a thin tube-like structure which is coiled up under the head when not in use. When feeding, the insect uncoils the tube and inserts the tip into exposed fluids which are then sucked up the food channel.

Examples: moths and butterflies.

Chewing Lapping Insects

These insects have mouthparts consisting of jaw-like structures used for chewing and, in addition, an elongated tube that forms a tongue-like structure for lapping fluids.

Examples: honey bees and bumblebees.

LIFE CYCLE DEVELOPMENT OR METAMORPHOSIS

All insects develop from eggs which may be stored inside or outside of the parent's body prior to hatching. They are usually laid in protected areas that provide good conditions for survival of the young when they hatch.

Once an insect hatches, it grows through a series of stages. As the insect develops, it lays down a new skeleton direction under the old one. The old body wall splits and the new one emerges and expands to a larger size before hardening. This is called "moulting" and it occurs 4 - 8 times.

Often the appearance of the insect changes between moults. This is a process called metamorphosis. There are three distinct life cycles:

Gradual metamorphosis:

There is just a gradual change in size and shape of the insect. The three stages of the life cycle are egg, nymph (several stages) and adult. The nymph stages are called "instars". The nymphs look similar to the adults and have the same food preference and manner of living. If wings are to develop, they only appear at the adult stage. NOTE: In some publications this life cycle may be referred to as "incomplete metamorphosis".

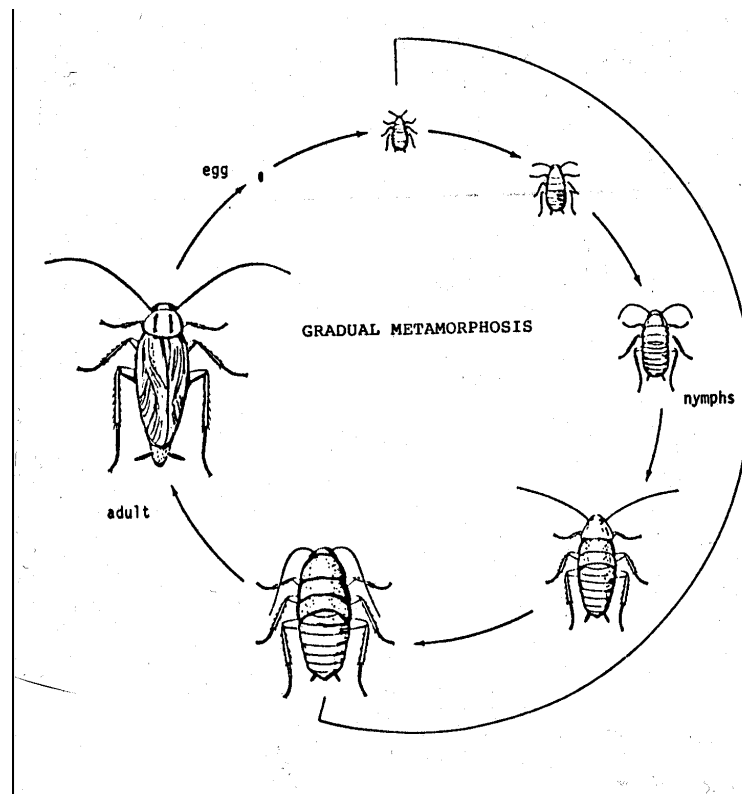

Complete metamorphosis:

This involves a drastic change from the young that emerge from the egg to the final adult. The insect goes through four distinct stages: egg, larva, pupa, adult. The larva will likely moult several times as it grows. This stage usually looks like a worm or caterpillar. It is the fastest growth stage and usually capable of doing the most damage. The pupa is a resting stage for the insect prior to becoming an adult. During this stage, the adult antennae, legs and wings form. The pupa does not move or feed and it is usually wrapped in a protective coating called a cocoon. When fully developed, the adult insect emerges from the pupal case. It no longer resembles its earlier stage. Most have developed wings. This stage can continue to do damage to the same plant the larvae fed on, but usually the adult becomes more of an annoyance for man or vector for disease.

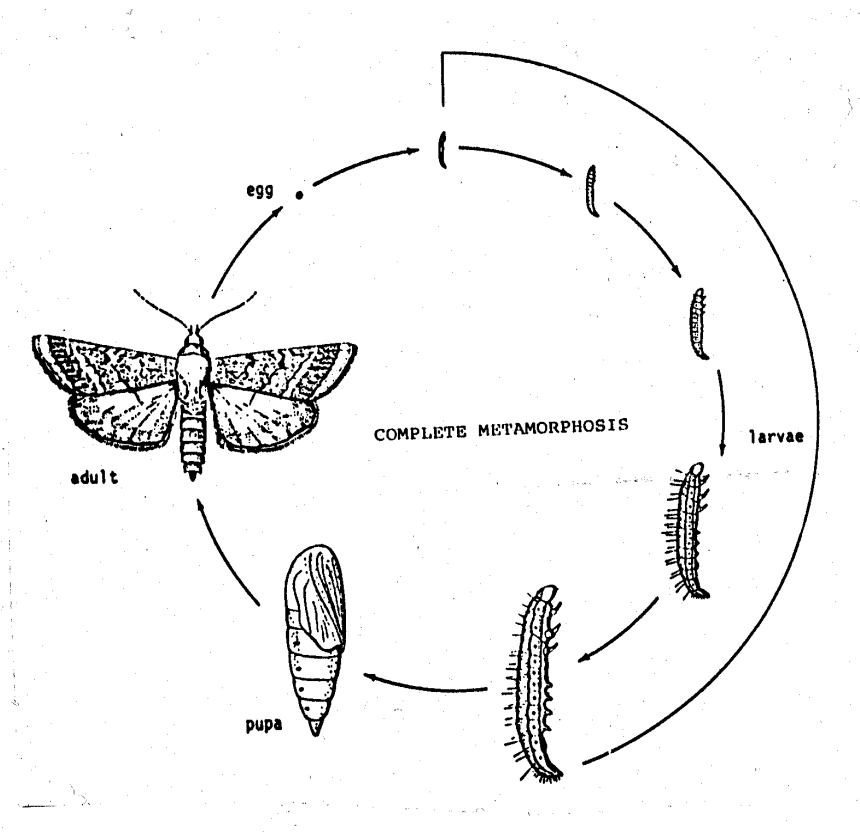

Without metamorphosis: Some insects progress from egg to adult with the exact same features. Each moult only allows them to get larger. The adult differs from the young in that it is sexually mature.

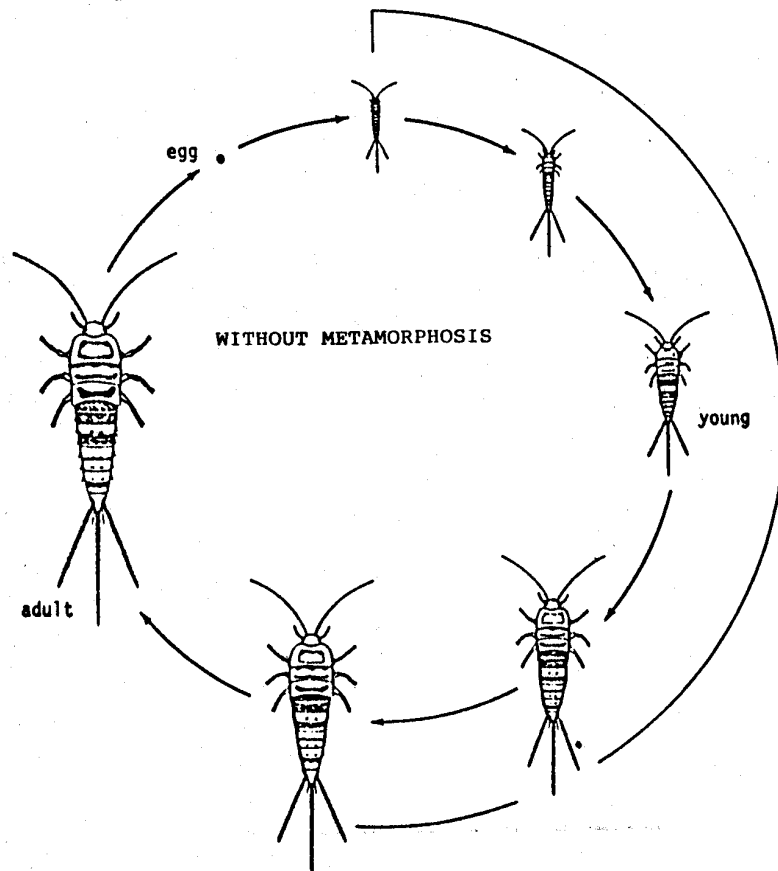

INSECT PESTS

Aphids

Aphids are also referred to as plant lice. They are generally less than 3 mm long and have long legs and antennae. There can be a variety of life cycle stages present in a greenhouse at one time with colours ranging from black to grey, red, yellow or green. The adult may be winged or wingless.

The most common species of aphid in greenhouses is the green peach aphid, *Myzus persicae*, which attacks a number of plants. Other aphid pests include the foxglove aphid, *Acyrtosiphon solani* and the potato aphid, *Macrosiphum euphorbiae*; both of which also have a wide host range.

Aphids occur in large colonies on new growth, at the base of buds and on the underside of leaves. In addition to sucking the plant juices and distorting growth, they excrete honeydew and also transmit a number of viral diseases. Most aphid species found in greenhouses do not mate. The virgin females, winged or wingless, may give birth to 60 - 100 living young (nymphs) over a period of 20 to 30 days. A newly born nymph begins to reproduce as a virgin female in about 7 to 10 days. Winged females appear when the colony becomes overcrowded or the food supply is depleted. These females migrate to new host plants. The appearance of true sex forms, which mate and lay eggs, usually occurs outdoors with the beginning of the cold weather. The egg is the outdoor overwintering stage. Aphids can reproduce year round if suitable host plants are available in a greenhouse.

A good control program requires continuous surveillance to eliminate initial aphid infestations on the host plants before these reach blossom and/or marketing stages. When applying foliar insecticides, thorough coverage of the infested plants is necessary because young aphids can hide in leaf buds, flower buds and under leaves.

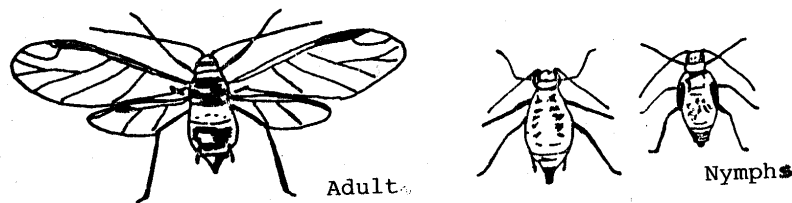

Fungus Gnats

Fungus gnats, *Sciara spp.*, are black, tiny delicate flies that are more of a nuisance than a threat. The grey-black adult fly (a) is about 4 mm long. The adults are weak flyers and are often found resting on the media surface in the containers. The adult gnats do not feed. Each female lays between 150 and 170 oval white eggs in or on the organic matter of the media. These hatch in 2 to 7 days, depending on the temperature to produce small 4 to 6 mm long white legless larvae (c). The larvae have 12 segments and shiny black heads. They feed on decaying organic matter and young roots of plants. The root feeding can lead to root rots. It also reduces the plant's absorption of nutrients and water.

The larvae spin pupal cases (b) and remain immobile in the soil for 4 - 6 days, after which the adult flies emerge. The

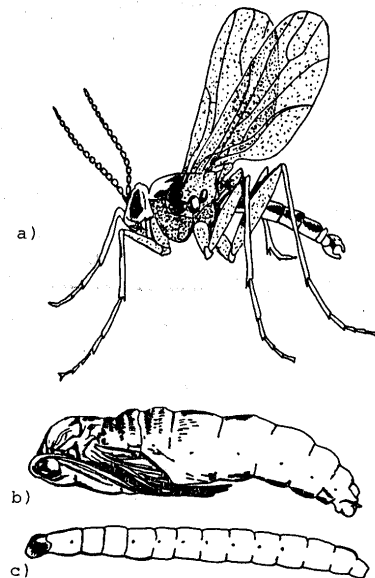

life cycle can be completed in 21 days at 24°C or 38 days at 16°C. This allows fungus gnats to multiply quite rapidly, if not held in check.

The gnats enter the greenhouse either on infested plants, potting soil or by flying in from adjacent areas outside. Sanitation within, as well as outside the greenhouse, is important. Soil drenches or soil applications of granular insecticides, either as control or preventative measures may be necessary to protect plant material most susceptible to infestation (poinsettia, geraniums, begonias, African violets and bulbs) especially when these are grown in soil rich in organic matter, sphagnum moss or peat pots.

Leaf Miners

Leaf miners, when in the larval stage (**c**), tunnel between the outer layers of leaves making unsightly tunnels. A heavy infestation renders the plant useless for sale.

The adult female of the chrysanthemum leaf miner, *Phytomyza syngenesiae*, (**a**) is a stocky fly about 2 mm long. It punctures the leaf surface with a tube-like appendage on the abdomen and inserts eggs into the leaf. This activity creates small white spots on the leaf (**b**). A larger number of punctures are made than the number of eggs deposited. Each female lays about 100 eggs in its two to three week life span. The egg hatches in five to six days into a soft white

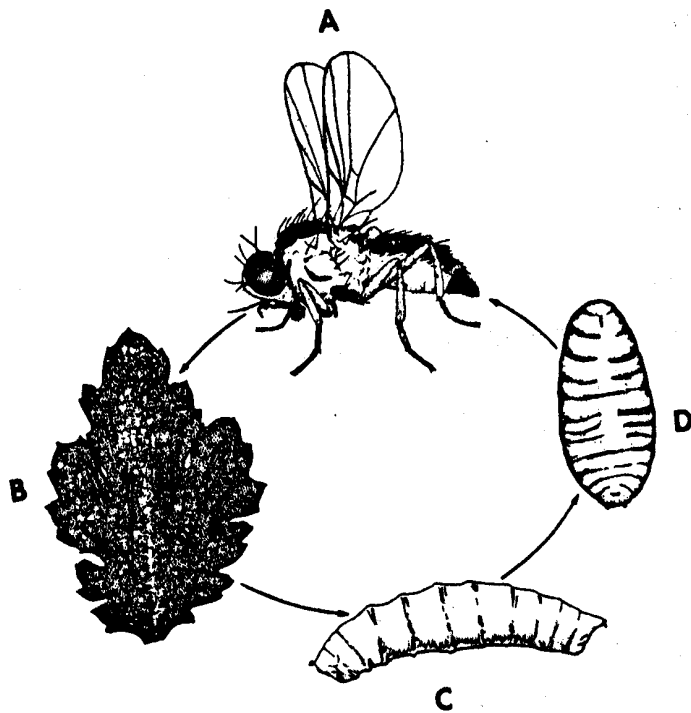

maggot which reaches 2.5 mm long when mature. The maggot can tunnel for up to two weeks before it turns into a pupa (**d**). After about two weeks, an adult fly emerges, flies to a new leaf and the life cycle begins again. About five weeks is required for the life cycle from egg to adult.

Mealybugs

Mealybugs (*Pseudococcus* spp.) are oval-shaped insects with a white wax-like powder which covers their bodies. These insects are about 3 mm long. Adult male mealybugs are delicate two-winged insects which do not feed.

Mealybugs feed by means of a piercing, sucking mouth part. During feeding, **citrus mealybugs** inject a toxic substance into the plant. The plant may become chlorotic or chlorotic spots will be present. Like aphids, mealybugs secrete honeydew which provides a substrate for the growth of a black sooty mould.

Long-tailed mealybugs give birth to living nymphs. **Citrus mealybugs** deposit yellowish or orange eggs in a cottony sac. The eggs hatch in 5 - 10 days into nymphs. The nymphs move about feeding for 6 -8 weeks. The life cycle from egg to adult takes seven to ten weeks under favourable conditions.

The waxy protective layer makes it difficult to control mealybugs. Nymphs have a thinner protective coating and are easier to kill than the adults. The addition of a surfactant to wettable powder formulations will help to counteract the water repellent nature of the waxy secretion of the insect. Surfactants and spreaders will help get the insecticide into cracks and crevices where mealybugs hide.

Root feeding mealybugs may be found within masses of wax on the roots of wilting or yellowed plants. These insects are much like those described above except that they have less wax over their bodies. The crawler stage may spread to other plants through contaminated equipment or water. Most infestations result from introduced material that was contaminated. Inspect all plant materials entering the greenhouse for mealybugs. Systemic granular and drench insecticides are the most effective for controlling these insects.

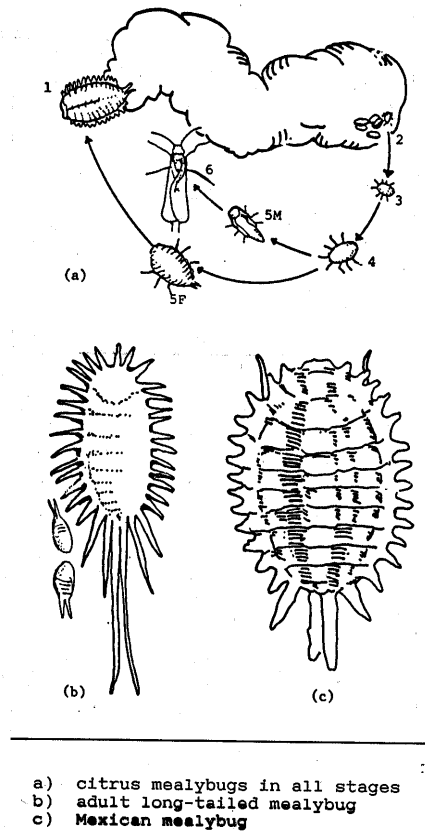

Mites

Mites are very small, wingless creatures. **They are not insects** but are related to spiders and ticks (arachnids). The two most important pest species in greenhouses are the two-spotted spider mite, *Tetranychus urticae*, and the cyclamen mite, *Steneotarsonemus pallidus*.

The two-spotted spider mite attacks a wide range of floricultural crops. The eight-legged female adult mite is approximately .50 mm long with a rounded abdomen. The male can be

distinguished from the female by its smaller, narrower body and pointed abdomen. Close examination of the undersurface of the leaves will show the mites to be very tiny moving dots. The two dark spots on the body are the food contents showing through the transparent body. The body is sparsely covered with spines. After mating, each female mite lays approximately six pearly-white eggs per day. Over an average lifetime, 100 or more eggs are laid by a female on the undersurface of the foliage. The newly hatched mites pass through the typical six-legged larval, protonymph and deutonymph stages. The deutonymph is an immobile resting stage and hence, a very difficult target for miticides. The life cycles from egg to adult ranges from 23 days at 15°C to only 7 days at 27°C. Development is rapid under hot, dry conditions.

Two-spotted mites are found on the underside of foliage. All active stages feed through sucking mouthparts by piercing the lower epidermis. The feeding injury is characterized by pale dots on the upper leaf surface. When there is a well advanced infestation webbing is produced over the foliage and flowers. If infestations are allowed to proceed without control measures, plants may be killed. Mite populations explode at certain times of the year because the life cycle varies considerably with temperature. Other factors including relative humidity, plant nutrition and plant cultivar are also important. These mites prefer low relative humidity and temperatures over 20°C.

As with other greenhouse pests, continuous vigilance on the part of the grower may prevent costly surprises. Two-spotted spider mites infest many outdoor ornamentals and weeds, thus they can easily migrate into greenhouses from adjacent vegetation. Infestations develop most rapidly on plants near steam pipes or other objects which radiate heat. Although several miticides are available, chemical control is usually very difficult. It is impossible to control mites established in open blossoms without injuring the saleable product. Miticide application to greenhouse cucumbers must be timed to avoid conflict with the pre-harvest interval as stated on the labels. The use of predacious mites (mites that feed on other mites) is receiving much attention. This biological control technique requires more management time on the part of the operator. It should be integrated with miticide applications.

Cyclamen mites are microscopic in size. They are not as common as two-spotted spider mites but they are just as destructive to host plants (e.g. cyclamen, African violet, strawberry, ivy) if not detected early and controlled. These mites prefer to feed and multiply in buds and surrounding young leaves. The damage, which is usually the first sign of their presence, may appear as splitting of buds, curling of leaflets from the outside inward and/or wrinkling of leaves so that pockets and pit-like depressions are formed. Cyclamen mites prefer high relative humidity (80 - 90%) and temperatures around 15°C. The entire life cycle is completed in 4 to 6 weeks.

Prevention and control of cyclamen mites is the same as that for two-spotted spider mites. Unlike the latter, cyclamen mites do not survive outdoors, but enter greenhouses exclusively on infested plant material.

Stages of the Two-Spotted Spider Mite:

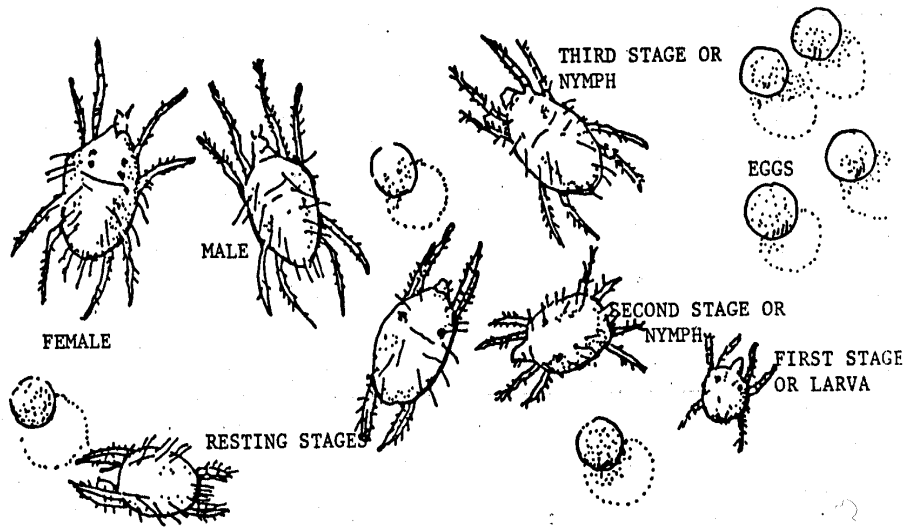

Scale Insects

Scale insects derive their name from the scale-like appearance of maturing nymphs and adult females. They are minute wingless insects up to 3 mm long. They have piercing-sucking mouthparts which they insert into the stems and leaves of plants and extract the plant juices. They have an oval body shape similar to their relative the mealybug. Unlike the mealybug which is mobile, scale is only mobile during the **crawler** stage immediately after hatching. Once the female crawler has settled at a suitable feeding site, it secretes a characteristic waxy scale-like covering over its body. The males, which are rare, develop wings.

Two commonly encountered scale insects found on many greenhouse plants are the hemispherical scale, *Saissetia coffeae*, and the soft scale, *Coccus hesperidum*. The hemispherical scale has a reddish-brown rounded shell about 6 mm in diameter. The soft scale is the same size but it is flat and yellow-brown in colour.

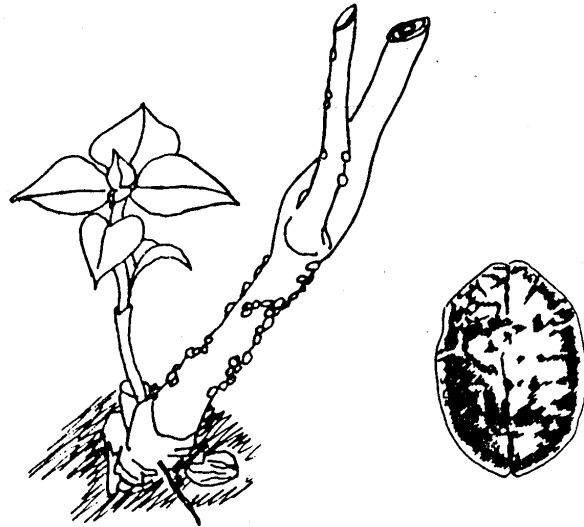

The females might lay up to a hundred eggs under their scale. When these hatch, small crawlers migrate to new feeding sites. Damage is caused by the removal of sap from the plants, causing yellowing and wilting.

The females are difficult to control if they have secreted their waxy shell.

Thrips

Thrips are very tiny, slender insects that occasionally infest greenhouses. They enter either on imported plants or migrate indoors from nearby native plants. Due to their small size, hiding habits and ability to multiply rapidly, they usually do considerable damage before they are discovered. Thrips feed by scraping the surface of plant cells and sucking up the escaping juices. The injured areas of the plants turn white and this produces the silvering, blotching and streaking of the foliage and flowers. Another typical sign of thrips presence is the appearance of small, globular brown/black drops (excreta), about half the size of a pin head, on infested foliage.

To find thrips, look under bud scales, in open blossoms and in pollen sacs, down the axils of leaves, under bulb scales, etc. Another method of detecting their presence is to tap the suspect plant on the palm of the hand or on a piece of white paper. Adults are dark coloured; nymphs are yellow to tan in colour.

Female thrips lay their eggs in host issue. In 5 - 6 days, the eggs hatch and form pale white wingless nymphs which begin feeding immediately. They move about on the host plant and to adjacent plants. Shortly before changing into adults, they stop feeding and spend some time in the soil. The entire life cycle will be completed in 2 to 4 weeks, depending on greenhouse conditions. All stages can be found throughout the year in greenhouses.

Three species of thrips that have caused damage to greenhouse ornamentals are onion thrips, *Thrips tabaci*, gladiolus thrips, *Taeniothrips simplex* and greenhouse thrips, *Heliethrips haemorrhoidalis*. Onion and gladiolus thrips occur outdoors. Greenhouse thrips are usually imported on infested plant material. All three species have a broad host range and thus can do widespread damage if not detected early.

The use of insecticides for thrip control is limited by the sensitivity of flower parts to pesticide injury. Repeated and preventative fumigation or aerosol application may be necessary to protect flowering crops. Cultivation of host plants such as onions and gladioli, as well as chrysanthemum and other composites, should be avoided near greenhouses. Good weed control practices in and around the greenhouse are helpful.

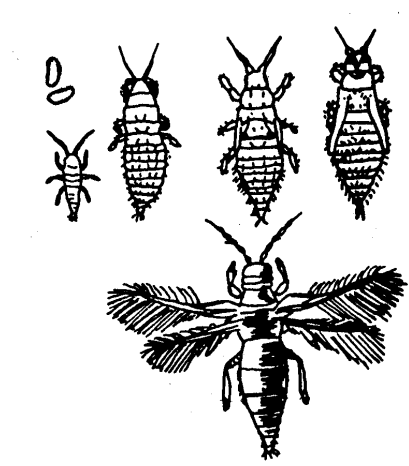

Whiteflies

The greenhouse whitefly, *Trialeurodes vaporariorum*, is a common and destructive pest of ornamental and vegetable greenhouse crops. Although it cannot withstand prairie winters, it readily infests and multiplies on outdoor plants during the summer months. In the fall, they will migrate back into greenhouses. It is very important to maintain good vegetation control around greenhouses to reduce as much as possible the migration of this pest back into greenhouses.

Mature whiteflies are tiny, white, four-winged insects, about 1.5 mm long. When disturbed they fly into the air like snowflakes. Adults and larvae feed by sucking plant juices from the underside of leaves. They secrete a great deal of honeydew similar to aphids and mealybugs. This can promote the growth of sooty mould. Severe infestations may also cause defoliation of host plants. Whitefly infestations are characterized by the presence of white, delicate cast-off skins on the upper surfaces of leaves, on the soil and on the bench surrounding infested plants.

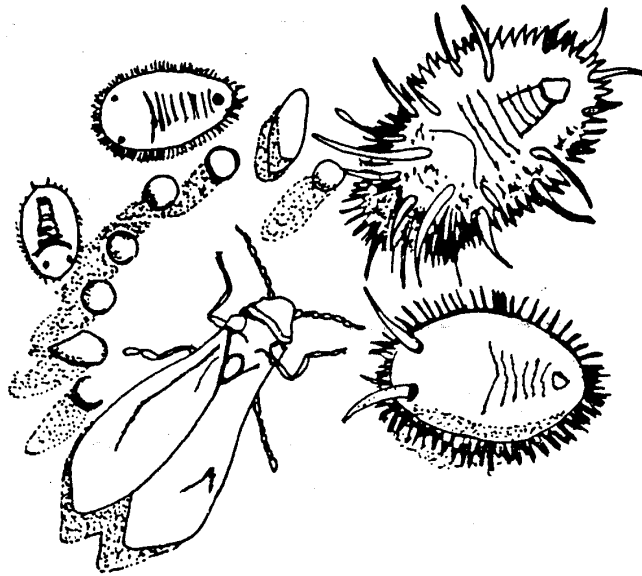

Females lay their tiny eggs in circles that appear as a ring of small black specks, usually on the new growth of host plants. Older developmental stages are found on the older leaves. The yellowish-green crawlers hatch in 5-10 days and migrate a short distance before settling down to feed. They soon lose their ability to move and become scale-like, flat and transparent to greenish yellow in colour. Within three weeks, they change into the non-feeding pupae, characterized by distinct black eyes and waxy thread-like projections extending from the margins of their plump bodies. The entire life cycle may be completed in four to five weeks.

Whiteflies have developed resistance to many groups of insecticides. A variety of insecticides should be applied to reduce the chances of resistance developing, especially if applications are made year round. Sub-lethal doses of insecticide promote the development of resistance so it is important that mixing and application instructions outlined on the pesticide labels be closely adhered to. Granular systemic insecticides and newer synthetic pyrethrins as foliar sprays have been shown to be highly effective in controlling this pest.

Integrated control of greenhouse whitefly is receiving more attention because of the resistance problem and the escalating costs of insecticides and application. Along with timely insecticide applications a tiny wasp, *Encarsia formosa*, can be introduced into an infested greenhouse to parasitize whitefly larvae and pupae. Female wasps lay their eggs in the pupae which become black and easily detected. The use of *Encarsia* is best suited to greenhouse operations in which plants are grown over sufficient time to allow the parasitic wasp to multiply and to achieve the degree of control of which it is capable.

INSECT CONTROL

The measures taken to control insects will be affected by environmental conditions, the specific insect to be controlled and its stages of development, the possibility of insect resistance to some insecticides, the susceptibility of plants to insecticides, the presence of non-target insects, the presence of insect predators, and the choice of insecticides.

Environmental Conditions

Control measures will be affected by environmental factors influencing the chemical itself, the insect pest and the plant that is being attacked.

Temperature — Chemical reactions take place more readily as temperature increases. Phytotoxicity can be a greater problem if increased temperature results in greater chemical absorption into the plant or if increased temperature results in the rapid evaporation of a spray solution concentrating chemical on leaf surfaces. At elevated temperatures, and especially under dry conditions, plant activity may be slowed which could affect the rate at which a systemic insecticide will be translocated.

The warmer the weather, the more active the insect will be. If an insect is feeding more actively, it will ingest more insecticide. conversely, pests tend to be more dispersed in warmer weather and this may hamper control efforts. Under cool conditions, insects may congregate together allowing you to direct an insecticide application for maximum effect.

Moisture — Insecticides usually work better under conditions of high relative humidity (RH). Diseases affecting insects are usually better adapted to high relative humidity. Some insects (e.g. aphids) function best when the humidity is low; liquid wastes are eliminated more efficiently.

Low RH when accompanied by high temperatures and ventilation could put plants under stress

and slow the movement of translocated insecticides. Low RH will also encourage the evaporation of spray solution on foliage and could result in foliage burning.

Sun/Cloud — Some chemicals are more subject to breakdown in the sun (photochemical breakdown). This could affect efficacy if the chemical had to remain on a leaf surface for a period of time.

The activity of some insects is affected by sunny or cloudy conditions. This could influence the probability of a spray application successfully intercepting a pest. The major effect of sun/cloud on plants is related to food production and translocation. Photosynthesis and translocation will be greatest under sunny conditions (providing the plant is not under stress).

Insect Identification

In order for any insect control measure to be effective, it is important that the pest be properly identified.

Lifecycle

The life cycles and feeding habits of the various stages of development are important to know and to identify if effective control measures are to be developed. By recognizing at which point in the life cycle an insect is most susceptible to a pesticide, the most effective control program can be implemented. Egg and pupal stages of insects are difficult to control as these stages do not feed and will not ingest a pesticide. They also have protective coverings to prevent the surface contact absorption of chemicals. Some adult insects do not feed, therefore systemic and stomach insecticides will have no effect on them. Contact insecticides must be used to control these adults.

Insecticide Resistance

At each pesticide application, naturally resistant insects survive while susceptible insects die. Soon, the entire breeding population consists of resistant members. Although resistance problems cannot be completely eliminated, they can certainly be reduced by understanding the following contributing factors:

Repeated use of the same insecticide — The change of resistance developing in areas where insecticides are used regularly can be significantly reduced by alternating two or more different insecticides from different chemical groups. Because the biological activities of chemicals within a particular group are very similar, any resistance problems identified for one chemical would be expected for each group member. Resistance problems can be extended to chemicals in different chemical groups if biological activities are similar (e.g. if the two pesticides both affect the functioning of a particular enzyme). Monitor your spray programs carefully so that you will be aware when resistance problems begin developing. Resistance should be suspected when the frequency or application rate of spray treatments must be increased to achieve control.

Spraying when not absolutely necessary — Any insecticide that is applied when an insect population is not at a critical level is not only a waste of time and money, but it gives naturally resistant insect pests the opportunity to dominate the pest population. If the practice is carried on with a variety of pesticides, soon it will be very difficult to find an effective pesticide should a real pest problem develop. This is particularly true where pests receive extended exposures to the same insecticide and where the insects produce several generations over the same year.

Applying insecticides at rates below label specifications — Applying any pesticide at a lower than specified rate is a poor practice. First, you probably will not get very good results; and second, you will be leaving a larger "starter" population of resistant insects.

Applying insecticides that are not very selective — This practice can lead to a number of "surprises". When you are treating a pest problem, other potentially harmful insect pests can be exposed to your pesticide. Later, when these pests create problems, you may find that your insecticide is not effective even though you have never used this insecticide against the new pest before.

Susceptibility of Greenhouse Plants to Pesticide Injury

Before applying any pesticide, **read the label** for precautions and restrictions, mixing and application instructions, information on pest insects controlled and plants for which the product is specifically recommended. These precautions should be observed:

- Avoid spraying flowers and flower buds which are in an advanced stage of development.
- Do not mix two or more pesticides unless the practice is approved on the label.
- Avoid closely spaced applications of one or more pesticides. Residue build-up and/or chemical incompatibility may result in plant injury.
- Make applications during the cooler hours of the day unless the chemical loses toxicity to target pests below a minimum temperature (e.g. do not apply malathion if temperature is below 20°C).
- Make sure plant surfaces are dry before spraying.
- Use mixed pesticides immediately.

Wettable or flowable powder formulations are generally less toxic to plants than emulsifiable concentrates. Other materials in the products, such as emulsifiers, wetting agents and solvents, may be responsible for plant injury. Several factors can influence the susceptibility of plants to pesticides:

- Conditions of cultivation (soil composition, fertilizer treatment),
- Climatic conditions (humidity, temperature, light),
- Age of plant or plant parts (young plant parts are more susceptible to injury),
- Variety and cultivar of a plant species,
- Injury by pests, and
- Plant vigour or general health.

Injury to plants after pesticide application is manifest in a variety of ways: complete foliage burning; marginal burn or spotting of foliar and/or flower parts; cupping, curling and yellowing of foliage; and distortion of buds.

Insecticides applied as soil drenches can cause similar injury symptoms. There may also be growth retardation (stunting) due to root injury.

Pesticides may be sold under a variety of trade names. Check the front of the label for the GUARANTEE statement or make sure the product you wish to use contains the correct active ingredient listed by its common name. Some products contain two or more active ingredients. Before applying the product, ensure the plant to be sprayed is tolerant to all active ingredients in the formulation.

Non Target Insecticide Action

Although many insecticides are selective, even selective insecticides are not usually specific to only one insect pest. Other insects, desirable as well as undesirable, can be harmed by an insecticide treatment. Problems can arise when insect predators are destroyed. If insect predators are to be used in an integrated control program, the timing of insecticide application and the mode-of-action (method of chemical uptake by the insect) for the pesticide must be considered.

Choice of Insecticide

When selecting an insecticide, consider the following things:

- Which insecticides are registered for use against your pest problem? Be sure that a registration is good for both the insect and the plant or crop being treated. If a particular use is not indicated on a label, although similar uses are listed, contact the chemical manufacturer to see about your proposed use.
- How toxic is the insecticide that you want to use? What safety equipment must you use to apply the pesticide? How close will your application be to people? Is a safer formulation available?
- What sort of residual activity can you expect from the pesticide? Will it control your problem for several days or several weeks? How long will non-target insects and humans be susceptible to inadvertent poisoning from contact with your treated areas? If you are treating a food crop, how long must you wait for treatment to harvest?
- Is the insecticide highly selective or is it more broad spectrum? Will you be harming beneficial insects that could help keep your insect pest in check? Is a formulation available which could reduce non-target effects? If a choice is possible, select the insecticide with the greatest selectivity if you are only trying to control one pest.

- What precautions are listed on the pesticide label? Is the chemical corrosive or abrasive? Does it have any other properties that could affect your application equipment? Are there any special storage requirements? Are there any particular health hazards or use restrictions?

SECTION 2 - GREENHOUSE PLANT DISEASES

PLANT DISEASES

Some diseases can be prevented if they are recognized early or their impact can be reduced if appropriate control recommendations are followed. To understand the reasons for control recommendations, it helps to know something about the diseases and the agents that cause them.

A disease is a disturbance in function accompanied by the appearance of symptoms. Examples of symptoms include: wilting, root and stem rots, cankers, damping-off, stunting, spotted or deformed leaves, fruit decay and other evidence of an abnormal condition. Whether the disease is important to us depends on how seriously it affects the quality of the plant.

The first step in combatting a plant disease is to recognize that a problem exists. Next, identify the casual agent and determine whether it is non-infectious or infectious. The following are some important points to remember in diagnosing diseases of greenhouse crops:

- An accurate diagnosis is essential before appropriate control measures can be applied.
- Look for clues in cultural practices and unusual growing conditions. Do not assume that an infectious agent is the cause of the disease.
- Know the crop. Many disease problems, especially non-infectious ones, can be prevented if one knows the growth characteristics, nutritional requirements and optimal environment conditions.
- Learn to recognize the signs of insect and mite infestations. They can be confused with symptoms of certain diseases.
- Close observation of the symptoms should indicate the general type of disease (e.g. leaf spot, wilt, root rot). Close examination of the surfaces of spots or cankers with a magnifying glass will often reveal the presence of spore-bearing bodies of fungi, bacterial exudates, insects or mites.
- Recognize your limits as a diagnostician. Consult a plant disease specialist if necessary.

INFECTIOUS DISEASES

There are four types of microorganisms which cause infectious diseases on greenhouse crops: bacteria, fungi, viruses and nematodes.

BACTERIA

Bacteria are some of the simplest living organisms known to man. Some are so small that 5,000 of them laid end to end would not measure more than one centimetre.

Each bacterium consists of a single cell. To reproduce, the cell divides into two other cells. These in turn divide into two more cells and so on. When conditions are favourable reproduction occurs so rapidly that more than a billion descendants may develop within a single day.

Some bacteria are beneficial to man. They feed on dead organic matter such as leaves on the ground and help build fertile soils. The conversion of ammonium and nitrite fertilizers to nitrate, the form in which nitrogen can be used by plants, is brought about by bacteria in the soil.

Bacteria can enter plants through natural openings, or through wounds, but only when the plant surface is wet for a period of length of time. Bacteria are brought to the plant by insects, water or implements during cultivation. Some bacteria are carried in or on the seed.

Bacterial diseases are difficult to control. A few bactericides exist. Control is primarily through prevention and elimination of infected plants. There are not as many bacterial diseases as fungal diseases. Some of the more common bacterial diseases are bacterial wilt of carnation; bacterial blight (stem rot and leaf spot) of geranium; soft rot of cuttings, corms, bulbs, etc.; bacterial leaf spots such as on geranium and English ivy; crown gall on rose, chrysanthemum, geranium, etc; and bacterial canker on tomato.

One of the most common symptoms of a bacterial disease in plants is rapid wilting. This occurs when bacterial cells plug the food and water conducting vessels in the plant. The plant usually dies as a result. Other symptoms are:

- blackening of plant roots
- rotting of stems, roots and leaves
- swelling of plant parts

FUNGI

Although fungi are plants, one feature separates them from green plants. Fungi have none of the green matter called chlorophyll. Other plants, because of their green leaves, utilize energy from the sun, carbon dioxide from the air and nutrients from the soil to manufacture their own food. Fungi cannot make their own food and must feed on other plants and organic matter.

Fungi are sometimes called molds. Although there are thousands of different kinds of fungi, the ones that attack living plants concern us most.

For the most part, fungi reproduce by spores, very tiny bodies that look and behave much like seeds. Each fungus is capable of providing millions of spores which are carried about by air currents, water, insects and unpasteurized soil. Only a very small percentage of the spores find their way to a leaf, flower or fruit surface on which they grow.

Under moist conditions, a spore landing on a susceptible plant can produce a new infection

centre. As the spore germinates, tiny thread-like strands develop and penetrate the plant surface. Sometimes these strands are able to pass directly through the leaf or fruit surface. More often, the plant surface must be injured before the fungus can enter. Injury of plant parts can be caused by insect bites, bruises, rubbing each other, and cultivation equipment.

Once a fungus penetrates the plant, it grows rapidly and branches hundreds of times forming a dense mass called **mycelium**. As the mycelium grows, it feeds on the plant cells causing the plant structure (leaf, flower, fruit) to weaken and a spot, rot, wilt or other symptom develops. Sometimes the whole plant is killed. Other times, only specific parts of the plant are injured. Some fungi produce substances that stimulate plant tissues and cause abnormal growth called **galls**.

Some fungi grow best at relatively high temperatures and high humidity, while other prefer a cool, moist atmosphere.

The fungal diseases are the most numerous and lend themselves best to control measures. Fungal organisms are much more complex than bacteria. Some of the more important categories are described below.

Powdery Mildew

This disease is characterized by the presence of the whitish, powdery mildew growth on surfaces of leaves, stems and sometimes petals. The fungal threads and the spores that develop on short, erect branches are visible under a strong lens. Under some conditions, however, the threads are so sparse that the mildew can be detected only by examination under strong light, with the use of a good lens or dissecting microscope. In some cases, the mildew development is limited to small areas in which the leaf cells are killed and turn black.

The mildew spores are easily detached and carried by air currents to surrounding plants where they initiate new infections. On some host plants, such as dahlia, zinnia and phlox, infection commonly is limited to older foliage later in the season and damage is chiefly the unsightliness of the mildew growth itself. On other plants, such as rose and delphinium, the young foliage and stems often become severely distorted in addition to being covered by the whitish mildew growth. Seriously affected plants maybe of little value as cut flowers or potted plants. Powdery mildew can be a problem in cucumber crops in the winter or spring.

Botrytis Blight

The grey-mold fungus, *Botrytis cinerea*, attacks a wide variety of ornamental plants, causing more losses than any other single pathogen. The fungus produces a brown rotting and blighting of affected tissues. Very small seedling asters can be rotted; stems of geraniums and begonias are attacked, snapdragon stems can be invaded and the upper part of the stem killed; petal tissues of many plants, including carnations, roses, chrysanthemums, azaleas and geraniums can be spotted and ruined. The fungus is usually identified by fuzzy, greyish spore masses over the surface of the rotted tissues under moist conditions.

Spores of *Botrytis* are produced on distinctive dark-coloured hair-like sporophores and are readily dislodged and carried by air currents to new plant surfaces. The spores will not germinate and produce new infections except in contact with water. This can be from splashing, condensation or exudation. With some possible exceptions, only tender tissues (seedlings, petals), weakened tissues (stubs left in taking cuttings, tissues, infected by powdery mildew), injured tissues (bases of cuttings) or old and dead tissues are attacked. Active, healthy tissues, other than petal tissues, seldom are invaded. It also attacks a wide variety of greenhouses vegetable crops (tomato, cucumber).

Root Rot Diseases

Rhizoctonia and *Pythium* not only cause damping-off of seedlings, but together with *Thielaviopsis* are very important in causing root and basal stem rots of older plants. These three fungi are common in soil and attack a very wide range of plants. Each is dependent for spread on mechanical transfer of mycelia, sclerotia, or resting spores in infected soil particles (on flats, tools, pots, baskets or in the end of the watering hose) or infected plant tissue. Basic control measures effective against one are also effective against the other two. Most important control measures are:

- Use of a light, well-drained soil mix
- Thorough pasteurization of the mix, containers and tools that come into contact with the plants
- Clean plants
- A sound sanitation program
- Supplementary soil treatments with chemicals to minimize recontamination problems.

Pythium causes a rather black, wet rot that makes roots look hollow and collapsed. It is favoured by cool, wet poorly drained soils. If *Pythium* is present, the soil should never be drained excessively.

Thielaviopsis causes a drier lesion than *Rhizoctonia*, one that soon turns black because of the large number of black spores of the fungus produced in the lesion. The disease is not a problem in soil adjusted to pH 4.5 to 5.0.

Wilts

The most effective control methods are the same as those for root rot disease.

Verticillium wilt — *Verticillium* is a fungus capable of infecting a wide variety of ornamental plants, some of the more important being chrysanthemums, China asters, snapdragons, roses, geraniums and begonias.

Symptoms vary with the host. Snapdragons can appear completely healthy until blossoms develop, when the foliage can suddenly wilt completely. The conductive tissues of some varieties can turn brown or purple, particularly the woody stem tissues. With chrysanthemums

and some others, there is usually a marginal wilting of the leaves. This is followed by chlorosis and eventually death and browning of the leaves, which remain attached and hang down against the stem. These symptoms commonly develop at first on only one side of the plant and only after blossom buds have formed. Young, vigorous plants usually remain symptomless. The buds on one or two branches of plants of red-flowered varieties of greenhouse roses turn blue and fail to open; the leaves and the green tissues can become mottled; and when the stem is shaken, the leaves can fall from the plant and the stem dies. Additional shoots can develop from basal buds and go through the same sequence, though eventually a shoot may remain healthy. Usually there is no vascular discoloration. With semituberous-rooted begonias, some yellowing of leaf margins can occur. The most distinctive symptom is development of an extremely shiny lower leaf surface.

The most characteristic symptoms are the one-sided development, the wilting and yellowing of leaf margins progressing upward from the lowest leaves, the lack of any leaf or stem lesions, and normal-appearing roots.

The fungus causing the disease invades the soil and may persist there for many years. Initial infection usually occurs through normal roots, and the fungus grows upward through the water-conducting (xylem) tissues. Infected plants of some types (for example, chrysanthemums) are usually not killed by the fungus, and during periods of rapid vegetation growth, can appear symptomless. Cuttings taken from such plants can, however, carry the fungus internally and serve to introduce the disease to new areas.

Fusarium wilt of tomato — The first symptom is a slight vein clearing on the outer, younger leaflets, followed by epinasty (twisting) of the older leaves caused by drooping of the petioles. When plants are infected at the seedling stage, they usually wilt and die soon after appearance of the first symptoms. Older plants may wilt and die suddenly if the infection is severe and if the weather is favourable for a pathogen. More commonly, in older plants vein clearing and leaf epinasty are followed by stunting of the plants, yellowing of the lower leaves, occasional formation of adventitious roots, wilting of leaves and young stems, defoliation, marginal necrosis of the remaining leaves and finally death of the plant. Often these symptoms appear on only one side of the stem and progress upward until the foliage is killed and the stem dies. While the plant is still living, no fungus mycelium and fruiting bodies appear on its surface.

Fruit may occasionally become infected and then it rots and drops off without becoming spotted. Roots also become infected and, after an initial period of stunting, the smaller side roots rot.

In cross-sections of the stem near the base of the infected plant, a brown-ring is evident in the area of the vascular bundles. The upward extent of the discoloration depends on the severity of the disease.

Damping Off

This disease affects seeds, seedlings and older plants.

Pre-emergence damping-off — The symptoms caused by the damping-off fungi vary with the age and stage of development of the plant affected. When seeds of susceptible plants are planted in infested soils and are attacked by the damping-off fungi, they fail to germinate, become soft and mushy, then turn brown, shrink and finally disintegrate. Infection can also occur after the seed has germinated but before the seedling has emerged about the soil line. Tissues of such young seedlings can be attacked at any point. The initial infection area enlarges rapidly. The seedling dies shortly after the beginning of infection. In both cases, infection takes place before the seedlings emerge. This phase of the disease is called pre-emergence damping-off.

Post-emergence damping-off — Seedlings that have already emerged are usually attacked at or below the soil line. The succulent tissues of the seedling stems are easily penetrated by the fungus, which invades and kills the cells very rapidly. The invaded areas become water-soaked and discoloured and the cells soon collapse. At this stage of infection, the basal part of the seedling stem is much thinner and softer than the higher non-invaded parts. The invaded portion of the stem cannot support the part of the seedling above it, and the seedling falls over on the soil. The fungus continues to invade the seedling after it has fallen to the ground and the seedling quickly withers and dies.

VIRUSES

These are smaller than bacteria. The tiny particles are so small they cannot be seen through an ordinary microscope. Viruses only reproduce when they are within other living cells.

Plant tissues cannot be penetrated directly by viruses. There must be a wound on the plant. Insects are an important means by which viruses are spread from one plant to another. Aphids, leafhoppers and other insects with sucking mouthparts are the most important virus carriers. Cigarette smokers are common carriers of tobacco mosaic virus and transmit it to tomatoes and other related plants. Viruses may also be carried in seed, tubers or bulbs.

The most common symptom of virus infection is stunting or dwarfing, leaves showing spots, streaks, blotches and rings of light green, yellow, white, brown or black or developing rather uniform yellow or orange coloration. Leaves can also be changed in size or shape; they can pucker or have rolled margins. Flowers can be dwarfed, deformed, streaked, faded, green instead of the usual colour, or even changed into leafy structures. When plants show no visible symptoms, virus indexing systems may help. These systems have been developed to detect plants that contain dormant viruses; they depend on special indicator plants (plants that always show visible symptoms when specific viruses are present, even if dormant).

Some Examples of Viruses:

- Chrysanthemum stunt
- Chrysanthemum mosaics
- Chrysanthemum chlorotic mottle
- Carnation mottle
- Carnation ringspot
- Carnation mosaic
- Carnation streak
- Tomato mosaic virus
- Cucumber mosaic virus
-

NEMATODES

Nematodes are slender thread-like organisms, some of which attack and feed on living plants. Because they look a great deal like tiny eels, they are sometimes called eelworms. Nematodes that feed on plants are small, usually from 0.5 to 1 mm long. Not all nematodes are harmful. For example, those that feed on decaying organic matter are useful because they help build fertile soil.

Plant nematodes may be found in stems, petioles, leaves or roots. Those that feed on the roots cause the greatest amount of damage. Only a few on the roots of one plant may cause very little damage, but when many thousands are clustered there, as often happens, the plant is greatly weakened and sometimes killed.

Many nematodes that feed on plants are equipped with a miniature hollow spear called a stylet. After they puncture the cells of the root with the stylet, they suck out the contents of the cells. Some nematodes actually enter the root and spend most of their lives there. Others remain outside the root. Even though only a few nematodes may be feeding on a single root, the wounds caused by their feeding may allow fungi or bacteria to enter and kill or seriously damage the plant.

Some nematodes form knots or galls on the roots of plants. These structures slow the intake of water and minerals from the soil and cause the plant to be stunted.

Root Knot Nematode

This is the most common of the nematode diseases. Six kinds of root knot nematodes are recognized in North America. Infected plants appear stunted and tend to wilt on warmer days. When such plants are dug, the root galls are easily recognized. The presence of galls does not necessarily indicate crop loss. With adequate moisture and fertility, infected plants may still grow and produce almost normally.

Other Root-attacking Nematodes

Chlorosis, stunted and unthrifty growth of above-ground parts of the plant are caused by other root attacking nematodes. Roots can be shortened, thickened, excessively branched to the point

of becoming matted and occasionally killed. Root galls are usually absent.

Leaf (Foliar) Nematodes

These cause leaf spots and defoliation. The spots are first noticeable on the lower leaf surface as small yellowish or brownish areas that eventually turn almost to black. With favourable conditions of temperature and moisture, they may spread until much of the leaf is destroyed. On chrysanthemums, the leaf veins slow the spread of the nematodes through the leaf, causing the lesions to be V-shaped or angular. Infection begins on the lower leaves and progresses upward. On peperomia, gloxinia, African violet and Rieger begonias, the lesions are less defined and infection may occur on any leaf. Unlike other nematodes, foliar nematodes do not persist in the soil in the absence of living host-crops tissues.

ENVIRONMENTAL DISEASES

Diseases may be caused by unfavourable conditions in the environment (non-infectious diseases):

- Low temperature (example, frost or chilling injury).
- High temperature (example, sun scald).
- Chemical injury (example, herbicide drift).
- Impurities in the air (example, improper venting of gas heaters).
- Lack of nutrients (example, nitrogen deficiency).
- Too much nutrient (example, manganese toxicity).
- Excess water (example, "wet feet" from lack of oxygen to the roots).
- Low water supply.
- Toxic soil conditions (example, a result of over-sterilization).
- Combinations of the above (example, blossom-end rot of tomato caused by low calcium and sudden changes in water supply).

DISEASE CONTROL - GENERAL

Not all plant diseases can be chemically controlled once they are present. It is much easier to prevent the occurrence or spread than it is to kill the disease-causing organism.

Having correctly diagnosed the plant disease, the next question is what to do about it. Prior to implementing a disease control program. The following questions should be asked.

- Can anything be done now? The control may be applied to the next crop.
- Is the injury enough to warrant a chemical control program? A few diseased plants in one corner of the greenhouse may not justify treatment unless there is a risk of disease spread.

- Is spraying worthwhile when foliage is heavily infected? Leafspots and mildews can be controlled only in the early stages of infection.
- Could injury have been avoided by planting resistant varieties?
- Do you have the equipment necessary for control, e.g. sprayers or equipment for injecting nematicides?
- Is the infection caused by a virus so that plants cannot be saved?
- Does the pathogen persist many years in the soil? Is it possible to rotate into non-infested soil or go to a different production system such as bags?
- Are the root knot nematodes the major problem? So many host plants are susceptible that either soil treatment with a nematicide or moving the plant to non-infested soil are the only practical solutions.
- Will the disease recur? Most diseases, once introduced, will tend to recur each year, but in varying amounts depending on environmental conditions. The grower should be expecting the recurrence and be prepared to treat before planting or on first appearance of symptoms when control measure will do the most good.
- What diseases require immediate treatment? Damping off diseases of seedlings must be dealt with immediately to save the seedlings as the disease spreads rapidly.
- Are there effective chemical controls or must cultural control methods be used (i.e. discarding plants with bacterial or viral infection)?

Cultural Control Methods

There are several important cultural practices for disease control which should be integrated into any greenhouse management program. These serve both preventative and eradication functions. Similar cultural control methods may be applied to specific diseases which are common to several crops.

Greenhouse producers must strive to provide environmental conditions which are a compromise between those which favour plant growth on one hand and hinder disease development on the other. Attention to such details helps to prevent the onset and spread of diseases as well as to reduce the need to implement an expensive eradication program.

Damping off, root and stem rots:

- Plant in a light, well drained, well prepared, pasteurized soil or rooting medium such as sand, soil, vermiculite, perlite or sphagnum moss. If pasteurized rooting media are not

available, apply fungicides and mix well into the media. Follow label recommendations for rates and whether pre- or post-plant applications should be made.

- Where possible, keep soil on the dry side.
- Avoid over watering, overcrowding and planting too deeply.
- Provide good ventilation and air circulation to reduce humidity.
- Water in the morning to allow plants and soil surface to dry before evening.
- Avoid over fertilization, especially with nitrogen.
- Irrigate with clean water.
- Do not sow seeds too thickly.

Grey mold, powdery mildew, rust and leaf spots (bacterial and fungal):

- Avoid placing the plants in damp, shady locations.
- Do not sprinkle foliage, particularly in late afternoon or evening.
- Take cuttings from healthy plants and disinfect tools between cuts.
- Provide good air circulation and raise night temperature to reduce humidity.
- Avoid over fertilizing, especially with nitrogen.
- Take cuttings off dry plants only.
- Do not use wet mulches.
- Space plants, especially "mother plants" to eliminate foliage contact.

Viruses:

- Propagate cuttings from healthy plants.
- Disinfect cutting tools between stock plants from which cuttings are taken.
- Avoid mixing old and new plants or plants from different sources.

- Keep insects under control, especially aphids.
- Space plants to eliminate foliage contact, especially "mother" plants used for cuttings.

Nematodes (root and foliar):

- Avoid introducing soil-borne nematodes from gardens and other greenhouses by strict sanitation procedures, including foot baths or overshoes for visitors.
- Avoid spreading foliar nematodes by not allowing leaves and stems to stay wet for long periods of time.
- Obtain root and foliar nematode-free stock.
- If possible, take soil samples and have them checked for plant parasitic nematodes. Careful representative sampling is essential if harmful nematodes are to be detected.

DISEASE PREVENTION AND ERADICATION

Sanitation

Sanitation should be an integral part of a disease control program. If a source of infection is constantly present, control measures may be expensive and ineffective.

- Remove and burn or bag up dead and drying leaves and flowers.
- Keep walls and the surface of beds and benches clean.
- Control weeds in and around greenhouses.
- Hang up the ends of hoses.
- When bringing new stock into the greenhouse, check carefully for possible diseases or insect infestations. Isolate new stock until you are sure it is healthy.
- Between croppings, spray greenhouse interior, walkways, packing house floor and tools with formaldehyde. Fumes are poisonous and must be thoroughly dispersed by ventilation before working in any sprayed area. Use an approved respirator when applying formaldehyde in confined areas.

Soil Pasteurization

This eliminates organisms that could be harmful to plants. Ideally, it can be accomplished with minimum injury to beneficial organisms. Soil should be moist, but not wet. The soil temperature at 15 cm depth must be 13°C or higher for successful treatment with chemicals.

Prevent recontamination of treated soil with disease-causing organisms by disinfecting all cultivating tools, pots, flats and other equipment which could come in contact with the treated soil. Plants grown in contaminated soil, or contaminated soil itself, should not be placed in treated soil. Plant only disease-free or fungicide-treated seed in pasteurized soil.

Bench and Equipment Sterilization

This should be a part of every greenhouse management program. To help eliminate disease organisms, all production equipment should be as clean as possible. Tools, potting benches, carts, walkways and growing benches should be sterilized between crops. For a general greenhouse clean up, use a commercial disinfectant such as household bleach, Mirasan, formaldehyde, etc. Growers should also sterilize automatic watering systems, equipment in the propagating area and clean their hands between crops or houses. If available, a steam hose is ideal to clean tools, wheelbarrows and other equipment. Knives used to make cuttings should be sterilized between individual "mother" plants.

Wood Preservatives

Copper 8-quinolinolate is the only preservative recommended for treatment for picking baskets and boxes, where contact with food is a possibility. Copper or zinc naphthenate, although not specifically recommended, have been used for the treatment of flats and benches in greenhouses. There have been several reports of damage to young plants where this material has been used for such purposes. In such cases the solvent rather than the active ingredient (copper) is phytotoxic.

Two commonly available wood preservatives, creosote and pentachlorophenol can be extremely

injurious to crops. Do not use these materials around or in a greenhouse.

FUNGAL DISEASE CONTROL

Prevention

It is practically impossible to kill a fungus which has infected plant tissues without injuring the host plant itself. In the life cycle of the fungus, the most susceptible stage is when the spore germinates. If leaves or seeds are coated with a thin layer of fungicide, the germinating spore is killed.

There is a time lapse between infection and visible disease symptoms (incubation period) which can be short or long depending on the fungal species and temperature. By the time the first symptoms are visible, many infections have already taken place. Disease situations are usually worse than indicated by first symptoms. One must look at past history of disease and seek advice from plant pathologists so that recognition can begin when the first infections occur. Treatments can then be undertaken when fungi are in their most susceptible stages.

Within a short time after symptoms can be seen, new spores are formed and are spread to surrounding plants.

Choosing a Fungicide

When choosing a fungicide, consider the following:

- What fungicides are registered for use against the disease? — Be sure that a registration is good for both the disease and the plant or crop being treated. If a particular use is not indicated on the label, although similar uses are listed, contact the chemical manufacturer.
- How toxic is the fungicide that you want to use? — Know what safety equipment must be used to apply the fungicide?
- How does the fungicide work? — How often will you have to reapply under wet or dry conditions? Plant diseases are usually more of a problem under wet conditions.

Some fungicides are applied to prevent diseases (protectant), and others can be used to eradicate diseases (eradicator). A few fungicides can be both protectants and eradicants.

Fungicides differ widely in their spectrum of activity. Some are very specific and will control only certain pathogens while others are broad in their effect. Some function only as protectants and they must be applied before the pathogen attacks, while others with eradicant action can be used where the disease is already established.

Some fungicides are systemic and others work only on the plant surface. How easily will it wash off? Young shoots that develop after a fungicide application will not be protected if the fungicide is non-systemic.

- What precautions are listed on the pesticide label? — How long is the interval between treatment and harvest? Is the chemical corrosive or abrasive? Does it have any other properties that could affect your application equipment? Are there any special storage requirements? Are there any particular health hazards or use restrictions?

Phytotoxic reaction and biological decomposition within the host must be considered when using fungicides to control plant disease.

NEMATODE CONTROL

There are several ways in which a nematode problem may be solved. Control often involves the integration of different methods. While chemical control is of primary concern here, sound practices which prevent introduction and spread of parasitic nematodes must be incorporated into a control program, otherwise chemical treatment may be useless and costly.

Most chemicals used in nematode control are fumigants. They move through the soil as gas and depend on the presence of open spaces in the soil for distribution. To obtain adequate control, it is necessary that soil conditions be such as to allow this gas movement.

The best time to apply chemical controls is when soil temperatures are high, moisture is moderate and there is plenty of time for killing action and the escape of the nematicide before planting. Immediately after treatment, the ground must be sealed to prevent escape of the gas before it has killed the nematodes. The ground should be worked up thoroughly before planting to allow any remaining phytotoxic chemicals to escape.

SECTION 3: USING BIOLOGICAL CONTROLS AND REDUCED RISK PESTICIDES

USING BIOLOGICAL CONTROLS AND REDUCED RISK PESTICIDES

The use of biological controls has become widespread in the production of greenhouse crops. Biological pest control in the greenhouse involves releasing natural enemies, such as parasites and predators, into the greenhouse to reduce the pest population. Parasites develop within the body of the target (host) pest(s) and eventually kill them. Predators attack and devour their prey. Parasites and predators are now widely available for use in greenhouse vegetable crops. Below are examples of pests that can be successfully controlled by this method.

- Whitefly is controlled by the parasitic wasp *Encarsia formosa*
- Two-spotted mite is controlled by the predatory mite *Phytoseiulus persimilis*
- Aphids are controlled by the predatory midge *Aphidoletes aphidimyza*
- Thrips are controlled by the predatory mite *Amblyseius cucumeris*
- Leafminer is controlled by the parasitic wasp *Dacnusa sibirica*

REDUCED RISK PESTICIDE REGISTRATIONS FOR GREENHOUSE USE

Expansion of the Pest Management Regulatory Agency's Minor Use Program has resulted in a number of new pesticide registrations for greenhouse producers including biological products and reduced risk pesticides. The following information was originally published online by the New Brunswick Department of Agriculture Fisheries and Aquaculture at http://www.gnb.ca/0171/40/bulletin_newsletter2005.pdf

Biological pesticides are typically microorganisms such as bacteria or fungi formulated and applied as a pesticide. Reduced risk products have different types of toxicity but meet criteria for low risk and environmental impact. This list is not complete and information has been summarized. Read pesticide labels fully before purchasing or using a product. Labels for all pesticides registered in Canada can be viewed at: <http://www.eddenet.pmra-arla.gc.ca/4.0/4.0.asp>

Biological Pesticides

- **Bioprotec CAF** (*Bacillus thuringiensis kurstaki*) for control of various caterpillars on greenhouse cucumbers, lettuce, peppers, tomatoes, chrysanthemums and roses.
- **Thuricide HPC** (*Bacillus thuringiensis kurstaki*) for control of various caterpillars on greenhouse tomatoes, chrysanthemums and roses.
- **VectoBac 600L** (*Bacillus thuringiensis israelensis*) for control of fungus gnats on greenhouse vegetables, herbs and ornamentals.

- **Mycostop** (*Streptomyces griseoviridis*) for suppression of seedling damping off and, root and crown rots on greenhouse tomatoes, cucumbers, peppers and many ornamentals
- **RootShield** (*Trichoderma harzianum*) for suppression of root diseases caused by Pythium, Rhizoctonia and Fusarium on greenhouse tomatoes, cucumbers and ornamentals.
- **Sporodex L** (*Pseudozyma flocculosa*) for control of powdery mildew on greenhouse cucumbers and roses.

Reduced Risk Pesticides

- **Avid** (abamectin) biologically produced miticide for control of mites and leafminer on greenhouse tomatoes, peppers, cucumbers and many ornamentals.
- **Confirm 240F** (tebufenozide) reduced risk chemical that mimics insect growth hormone. Registered for control of various caterpillars on greenhouse tomatoes, peppers, lettuce and many ornamentals.
- **Decree 50 WDG** (fenhexamid) a reduced risk fungicide for control of gray mould on greenhouse tomatoes and many ornamentals.
- **Endeavor 50WG** (pymetrozine) for control of aphids and reduction of whiteflies on greenhouse tomatoes, peppers and ornamentals.
- **Floramite SC** (bifenazate) selective miticide for the control of mites on greenhouse and indoor ornamentals.
- **Microscopic Wettable Sulphur** (elemental sulphur) for control of powdery mildew on greenhouse tomatoes, peppers and cucumbers
- **Sluggo** (ferric phosphate) for control of slugs and snails in greenhouses.

SECTION 4: GREENHOUSE PESTICIDE APPLICATION METHODS AND EQUIPMENT

SAFETY PRECAUTIONS DURING APPLICATION

Many different pesticides may be applied during the many different stages of production. When designing programs, the supervisor should choose the least toxic pesticide available. Only where no other pesticide will control the pest should the most toxic product be used.

Greenhouse workers spend considerable amounts of time handling plants in the greenhouse. Some crops require more labour-intensive management than others. When handling, there is always the potential for exposure to airborne residues still present after application and surface residues left on plants and equipment in the treated area. Employees should be aware that exposure through dermal contact can be just as dangerous as exposure through inhalation or ingestion if significant amounts are absorbed. Employees should shower after work and regularly wash work clothes. It is your responsibility to inform all employees of the potential hazard and the importance of protecting themselves.

APPLICATION

Pesticides used in a greenhouse are available in a variety of formulations. The formulation selected directly influences the application method and therefore the type of application equipment to be used.

Proper application of a pesticide depends not only on the correct method and equipment; it also involves the correct diagnosis of the pest problem, the correct selection of the pesticide to use, (assuming that the use of pesticides is the control measure to use), and finally, the correct application rate.

Application methods specific to greenhouse operations can be divided into the following types:

- high volume applications
- low volume applications
- smoke fumigation
- granular applications
- dust applications

It is important to realize that there **is a potential** for exposure to occur during all application methods. The safety procedures followed by the applicator before, during and after application will determine the amount of exposure he/she will receive.

HIGH VOLUME APPLICATIONS

High volume applications in a greenhouse are usually made with conventional hydraulic sprayers. These sprayers operate at high pressures between 300 and 400 psi (2.067-2.756 mega pascals) and disperse fine spray droplets into the air and onto the foliage. They are designed to apply pesticides to large areas. Applicators should adequately protect themselves with the appropriate respirator and clothing to avoid inhalation and dermal exposure.

A major concern with high volume spraying is the timing of the application. Even though workers may be at the opposite end of the greenhouse, they can still be exposed to the pesticide. To avoid unnecessary exposure to other workers, plan to spray in the early morning, the evening or on weekends when employees are not present. Check the label for the re-entry time before allowing employees to enter the treated **area. Never spray when unprotected workers are in the area.**

If the greenhouse is equipped with separate lines for pesticides, fertilizers and water, label the lines, keep them out of reach and let employees know of the system.

Pesticides are being applied in an enclosed space. Compared to outdoor applications, there is a greater risk of exposure to pesticides through the skin, mouth, ears or nose. Cover any exposed part of the body. Supplied air respirators provide a clean source of air during application.

Safety Before You Spray:

- Make sure everyone is out of the area.
- Close all doors, windows and other openings.
- Post warning signs on all doors to the area.
- Lock or barricade all entrances.
- Read the label.
- From the "precaution" guidelines given on the label, select the proper protective clothing and equipment for the product to be used.
- Put the equipment on properly.
- Open containers with a sharp instrument. Weigh powder formulations and measure liquids. Calculate the quantity of spray required to reduce the amount of spray mix that will be left over.
- Re-check the label for specific mixing instructions. Some pesticides must be premixed.
- Triple rinse empty containers and measuring devices.
- When filling the tank maintain an air gap between the hose and the solution to avoid back-siphoning of spray mix into the water line. Anti-backflow devices or check valves will also prevent back-flow problems.
- Make sure that everyone is out of the area. Tell the other workers in adjacent buildings when the area will be sprayed, which product will be applied and what the re-entry time is.

Safety While You Spray

- Start at the furthest end and work backwards. Spray both sides of the row. Never walk back through the treated area.
- When spraying with a wand above waist level, cuff the top of the glove. Put sleeve of coveralls inside glove. This prevents the spray from running down the gloves and onto the arm.
- When spraying overhead plants, spray from the next row yet to be treated. Direct the spray into the crop canopy.

LOW VOLUME APPLICATIONS

Low volume applications are generally made with:

- mist blowers (mechanical aerosol generators)
- thermal foggers (thermal aerosol generators)
- ultra low volume (ULV) applicators

Low volume sprays result in small droplet sizes. These fine spray droplets remain in the air much longer than the coarse spray droplets from high volume sprays. Although these droplets remain in the air much longer, low volume applications are usually made in the evening when only the applicator and an assistant are present. Workers are seldom exposed. The greenhouse remains sealed during the night, then is ventilated for one or two hours the next morning before workers enter. It is very important to ventilate before re-entry as residues can remain in the air throughout the night. Observe the required re-entry period outlined on the label.

In one particular study, applications of permethin made in the evening in a closed greenhouse resulted in fairly persistent airborne residue levels after the first two hour interval and until the vents were opened in the morning, 8-10 hours after application.

Ventilate the greenhouse for at least one hour before re-entry. The presence of pesticide residues in the greenhouse will depend on the efficiency of ventilation. Ventilation should replace the standing air in the greenhouse.

The following are some safety procedures to follow when applying low volume sprays:

Safety Before You Apply Low Volume Sprays:

- Make sure everyone is out of the area.
- Close all doors, windows and other openings.
- Post warning signs on all doors to the area.
- Lock or barricade all entrances.

Safety While You Apply Low Volume Sprays:

- Two people should be present, in case of an accident.
- Walk backwards, beginning from the furthest point, towards the exit.
- Seal the area for the time specified on the label.

Safety After You Apply Low Volume Sprays:

- Ventilate before workers re-enter.
- If it is necessary to re-enter, wear the proper protective equipment and clothing.
- While ventilating, keep workers away from exhaust fans.

LOW VOLUME EQUIPMENT

Mist Blowers

Mist blowers convert special pesticide formulations (usually liquids and wettable powders) into very small, fine droplets. This occurs when the pesticide is introduced into the path of an "air blast" generated by the mist blower. Although a single droplet cannot be seen, large numbers of droplets are visible as a "fog" or "mist". It is important to realize that air (not water) is the major pesticide carrier, therefore the concentration of the pesticide spray mixture is high. Care is required to prevent over-application since the higher concentration of the pesticide could cause injury to the crop.

Mist sprayers are very useful where thorough penetration of the crop foliage is necessary without unsightly residues remaining on the treated crop. Some greenhouse misters are automatic, therefore, the presence of an applicator is not required which increases the safety of application. Observe the required re-entry period outlined on the pesticide label.

"Mists" drift easily from target areas - always make sure that vents are sealed and doors are closed before treatment begins. Keep the operator, employees and animals out of the "fog" or "mist" cloud. Check that the pesticides you are using in the mist blower are registered for use and fill mist blowers with caution when they are set high in the greenhouse to avoid spilling the concentrate.

Thermal Foggers

Thermal foggers and mist blowers are often grouped under the same general heading. The primary difference between the two systems is that thermal foggers use heat to break up the pesticide into fine droplets. The "fog" produced is a relatively dry type of fog.

Fogging solutions are usually formulated at a lower concentration of the pesticide in an oil based carrier. Oil based solutions are necessary because water based emulsions will not produce the dry fog needed. Thermal foggers produce a dense white cloud that remains visible for a length of time. This makes it possible to know whether or not all areas were treated equally since the operator has an indication of where the pesticide is actually moving and settling.

During application never direct the fog towards the target plants. Oil based carriers and the hot exhaust may cause plant injury. Thermal foggers are available as hand held, back pack and automatic models. Follow the manufacturers recommended use and cleaning procedures carefully. The precautionary measures outlined under mist blowers also apply when using thermal foggers.

Ultra Low Volume (ULV) Applicators

Ultra low volume (ULV) applicators reduce the volume of pesticide mixture applied by reducing or eliminating the use of water or any other liquid carrier. Pesticides used are specifically formulated for ULV application and generally do not require further dilution (which is indicated on the product label). Droplets produced by ULV applicators remain in suspension for a considerable length of time, therefore the pesticide does not settle out too quickly and sticks to the target insect or pest more effectively. Horizontal air flow (HAF) is necessary in the greenhouse to obtain good coverage. The use of ultra low volume applications instead of fog or mist applications may be more desirable in certain instances.

The **advantages** of ULV sprayers include:

The ULV applicators can be placed in the greenhouse and controlled by a time clock to spray at a specific time. This reduces the possibility of both employee and applicator exposure. Thorough ventilation of at least two hours is necessary prior to re-entry. Check the label for the recommended re-entry period.

Labour and time saved due to the elimination of water.

Equal control with possibly less pesticide.

Deeper insecticide penetration into nooks and cracks, therefore providing more thorough control of crawling insects.

Only a limited number of pesticides are registered for ULV use. Spraying the concentrated pesticide increases the risk to the applicator. Remember to wear the proper protective clothing and equipment.

SMOKE FUMIGATION

Many pesticides are able to withstand intense heat without adverse effects. This property may be used to create combustible formulations that will ignite to form a pesticide smoke which will penetrate throughout the greenhouse.

The use of smoke fumigators requires no special application equipment. The pesticide is contained in a small can which treats an area of 300 m³ or 10,000 ft³. These cans are punctured and ignited and left to burn within the sealed greenhouse.

Remember to wear gloves, a respirator and coveralls to avoid inhalation of smoke and dermal exposure. Protective clothing is just as important to wear when igniting the cans as it is to wear when venting the greenhouse. Smoke fumigation in a greenhouse should not be done if the weather conditions are windy and if the greenhouse temperature is less than 16°C or greater than 33°C. These conditions will limit the effectiveness of the smoke application. Always read the label when using smoke fumigators.

Procedure for Smoke Fumigation

- Read the label to learn if there are any plants which may be injured by the product applied.
- Determine the total number of smoke fumigants required. This is done by calculating the total greenhouse volume to be treated and dividing by the volume that one container will treat.
- Never work alone - no matter how small your operation. If an accident occurs this ensures that there is someone to carry the victim to safety.
- Make sure all applicators have the proper protective clothing and equipment.
- Plan the application procedure and inform all involved personnel of the plan. Practice the placement procedure and hand signals for communication.
- Start lighting the cans farthest from the exit and work towards the exit.

Lighting Instructions

- Shake can well before using.
- Punch holes in side of can (not the top).
- Ignite lighter at the 'wire' or 'handle' end. (A propane torch works well).
- Insert lighter through the can

APPLYING GRANULAR FORMULATIONS

Granular pesticide formulations are applied by specific applicators available for either band application, broadcast application or soil injection/incorporation. Spreaders may work in several different ways to deliver the pesticide including air-blast; whirling disks; multiple feed outlets; or soil injectors.

All granular application equipment is designed to apply pesticides without further mixing. Use an applicator that is easy to clean and fill and one that is equipped with mechanical agitation over the outlet holes. This will prevent clogging and helps keep the flow rate constant. Granular applicators are speed sensitive, therefore maintaining a constant speed will help obtain uniform distribution of the pesticide.

APPLYING DUST FORMULATIONS

Dusters are used to blow fine particles of pesticide dust onto target surfaces without mixing. The use of dust formulations in a greenhouse is limited because of the visible residue that remains on the plants. Dusts also drift easily and are difficult to control. Dusters range from simple devices to elaborate motorized structures. Mist blower attachments are available for simple conversion to a power duster. All dusters should be emptied frequently and cleaned thoroughly. Moisture in the air will cause dust formulations to harden inside the application equipment if it is not properly cleaned. Avoid drafts when using pesticide dusts since carry-over to un-targeted plants may occur.

RE-ENTRY

After applying most pesticides, workers may enter the treated area a short time later. Check the label for directions on how soon workers can enter the treated area and handle treated foliage. If re-entry occurs too soon, workers may be exposed to high levels of residues, which could cause pesticide related illnesses. Studies have shown that airborne pesticide residues are the highest immediately after spraying. If it is necessary to re-enter before the minimum interval has elapsed, proper protective clothing and equipment should be worn. **Make sure that the greenhouse has been adequately vented before entering.** To protect fellow workers from entering the greenhouse too soon and becoming exposed, follow these safety procedures:

- Post signs on all doors leading to the treated house. If possible, indicate the time the application was made and the pesticide used.
- Lock all doors until it is safe to enter the greenhouse.
- Ventilate the greenhouse before workers re-enter.
- Advise workers to wear long-sleeved protective clothing and rubber gloves to minimize skin contact after re-entry.

SECTION 5: CALCULATIONS FOR PESTICIDE APPLICATION

CALCULATE HOW MUCH PESTICIDE TO USE

Pest Management Recommendations for Greenhouse Crops, OMAFRA Publication 365, answers many commonly asked questions concerning pest identification, pesticide selection and calculations. This publication should be kept as a handy reference guide in your greenhouse operation.

The amount of pesticide you need is based on the output of your sprayer. By knowing exactly how much a sprayer is delivering per unit area, you can calculate how much pesticide you need.

Pesticide rates for greenhouse crops are usually given in litres, grams or millilitres **per 1,000 litres of water (unless otherwise stated on the label)**. Practical experience by growers has shown that 1,000 litres of spray mix will cover an average cut flower crop of approximately 4,000 square metres. For potted plants, 1,000 litres of spray mix will cover approximately 5,000 square metres of total greenhouse area. It is important to check that the proper amount of spray mix is being applied to the treatment area.

Greenhouse growers may also use pesticide rates in litres per hectare (L/ha); millilitres per hectare (mL/ha); grams per hectare (g/ha); or kilograms per hectare (kg/ha). Refer to the *Pesticide Safety Manual* for information on how to calculate the amount of pesticide you need using these rates.

Calculating volume for fumigation

To know the amount of fumigant you need, you must calculate the cubic volume (i.e. m³ or ft³) of the greenhouse. Usually two or more volume calculations are necessary because of the various shapes and parts of the greenhouse. The cubic volumes of the individual parts are then added together to give the total cubic volume. For example, the total cubic volume of the following buildings is the sum of the cubic volume of part (1) and part (2).

Even span

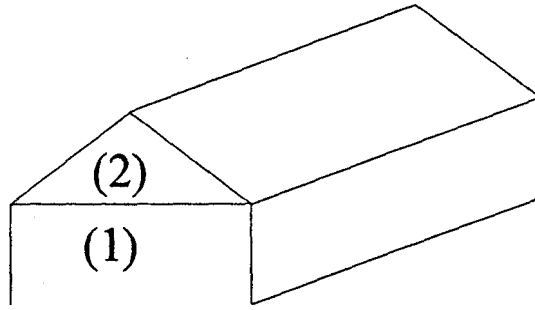

Uneven Span

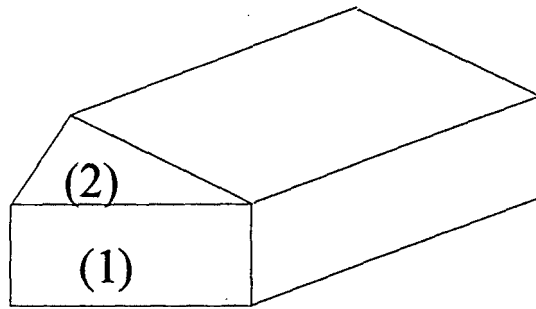

Quonset

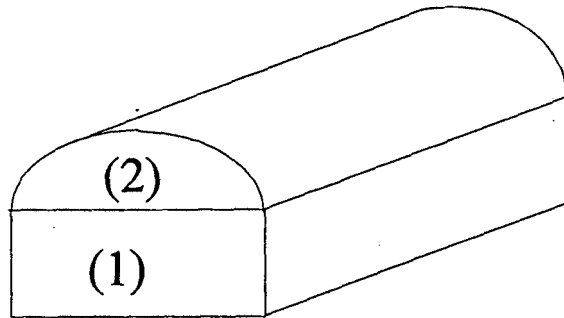

HOW TO CALCULATE THE VOLUME OF AN EVEN OR UNEVEN SPAN GREENHOUSE

Part 1- Rectangular Base

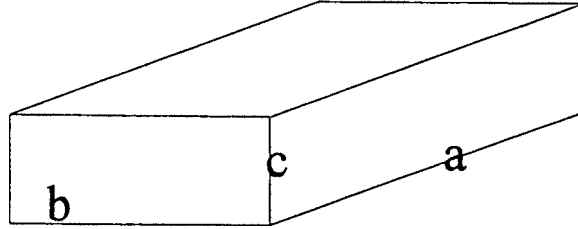

Volume = length x width x height or a x b x c

Example of a Rectangular Volume Calculation:

In metres:

a=30.5 m

b=4.6m

c=3.7 m

In feet:

a=100 ft

b=15 ft

c=12 ft

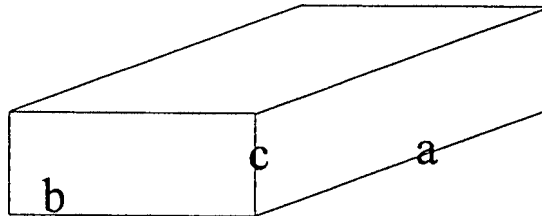

Volume
=30.5 m x 4.6 m x 3.7 m
=519 m³

Volume
=100ftx15ft
x 12 ft
=18,000 ft³

Part 2 - Even and Uneven Span

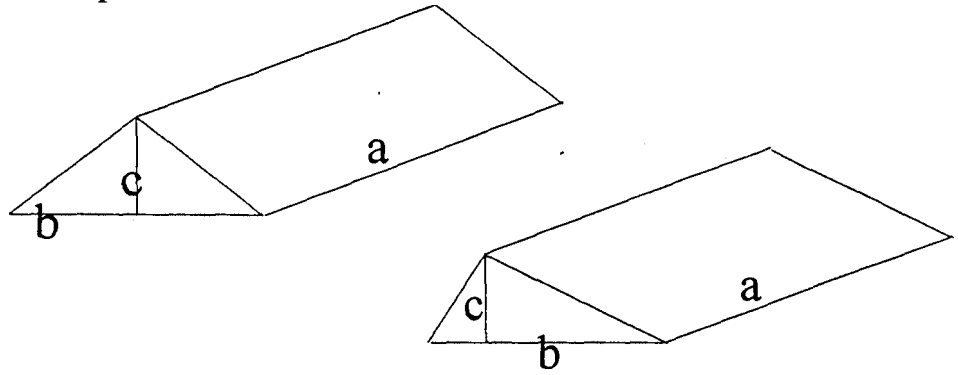

$$\text{Volume} = \frac{\text{length} \times \text{width} \times \text{height}}{2} \quad \text{or} \quad \frac{a \times b \times c}{2}$$

Example of an Even and Uneven Span Volume Calculation:

In metres:

**a=30.5 m
b=4.6 m**

In feet:

**a=100 ft
b=15 ft**

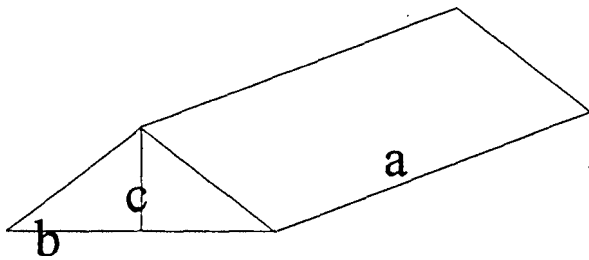

$$\begin{aligned} \text{Volume} &= \frac{30.5 \text{ m} \times 4.6 \text{ m} \times 2.5 \text{ m}}{2} \\ &= 175 \text{ m}^3 \end{aligned}$$

$$\begin{aligned} \text{Volume} &= \frac{100 \text{ ft} \times 15 \text{ ft} \times 8 \text{ ft}}{2} \\ &= 6,000 \text{ ft}^3 \end{aligned}$$

HOW TO CALCULATE THE VOLUME OF A QUONSET GREENHOUSE

Quonset

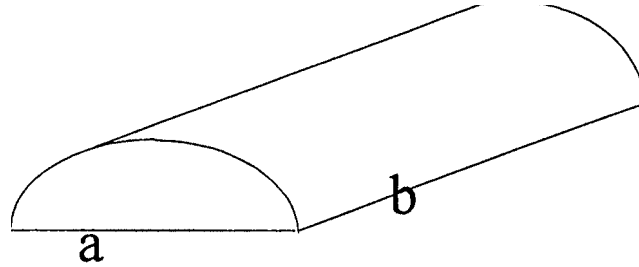

Volume = width x width x length x 11/28 or $a \times a \times b \times 11/28$

Example of a Quonset Volume Calculation:

In metres:
 $a=4.6$ m

In feet:
 $a=15$ ft

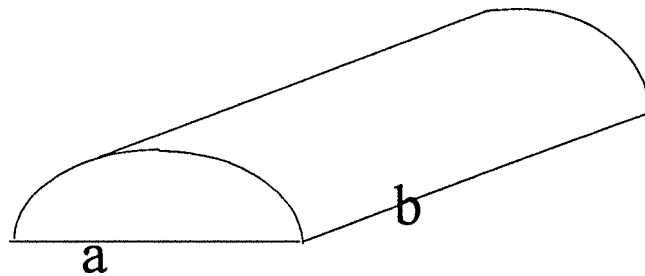

Volume
 $=4.6$ m x 4.6 m x 30.5 m x $11/28$
 $=254$ m³

Volume
 $=15$ ft x 15 ft x 100 ft x $11/28$
 $= 8,839$ ft³

SAMPLE CALCULATIONS - FUMIGATING BEDDING PLANTS

Greenhouse: 1 Quonset house Pest: white fly
Pesticides to use: Sulfotep Plant Fume 103 Smoke Fumigator
Rate: 1 can per 300 m³ to control whitefly
Greenhouse size: 5 metres wide, 31 metres long

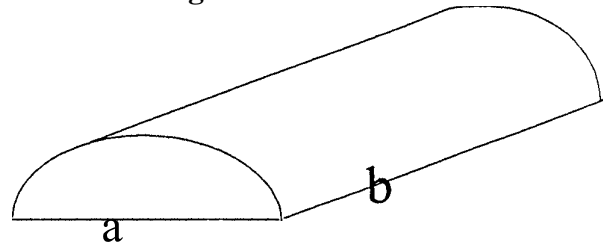

What is the volume in cubic metres of this greenhouse?

How *many* cans of Sulfotep Plant fume 103 are required to control whitefly?

SAMPLE CALCULATIONS - GREENHOUSE CUCUMBERS

Pest Problem: botrytis
Pesticide to Use: Rovral 50% WP at 1 kg per 1,000 L of water
Size of your spray tank: 50 L
Number of greenhouses to spray = 6
Size of each greenhouse = 7 metres x 30 metres

What is the total greenhouse area in square metres?

How many litres of spray are required?

How much Rovral will be needed to treat the entire area?

How much area does one full tank cover?

How much Rovral should you add to a full tank?

How many tanks will be required?

How much spray mix (Rovral plus water) is needed for the part (last) tank?

How much Rovral should you add to the part (last) tank?

ANSWERS TO SAMPLE CALCULATIONS

Bedding Plants

Greenhouse volume in cubic metres = 304 m³

1 can of plant fume 103

Greenhouse Cucumbers

1260 m²

32.15 litres

3.315 kg or 3315 grams

24.00 m²

55.0 grams

66.3 tanks

17.5 litres

SECTION 6 :PESTICIDE APPLICATION RECORD KEEPING

All pesticide users are strongly advised to keep thorough records of their crop production practices including pesticide applications. Records are important not only for personal protection, but also for management decisions. Records of pesticide usage help to protect you and your investment by providing the necessary documentation if a problem or question arises from a pesticide application.

Pesticide application records will help to:

- improve pest control practices and efficiency
- avoid pesticide misuse
- compare applications made with results obtained
- purchase only needed amounts of pesticides
- reduce inventory carry-over
- establish proper use in case of a residue question
- establish error if one was made
- establish proof of use of recommended procedures in case of lawsuits
- plan cropping procedures for next season
- plan pesticide needs for next season

Many different types of forms/charts have been devised for recording pesticide applications. Carry a pocket notebook with you and write down information as it happens - don't trust your memory. Later, this information should be transferred to a permanent record that's kept in your home or greenhouse

The following are the important factors to include when keeping records:

- location in the greenhouse - i.e. house number, bench number, etc.
- the size of the treated area
- the year, month, day and time the pesticide was applied
- crop treated
- the target pest(s)
- what pesticide was used - include trade name/common name, the registration number assigned under the PCP Act and the concentration of the a.i.
- the method of application/type of equipment used
- the rate of pesticide application
- stage of crop development
- weather/temperature conditions
- name of applicator
- results of application