

# Access Roads and Crane Platforms

## E-82

### 77m steel tower

**Document information:**

Author/date:	Heiko Krey/10.05.06	Translator/date:	-
Department:	Project Management	Revisor/date:	-
Approved/date:	Gunda Hinderlich/18.07.07	Reference:	PM-CW-SP023-E82-77m Zuwegung und Kranstellfläche- Rev005ger-eng

<b>CONTENTS</b>	<b>Page</b>
<b>1. Assembling the tower and wind energy converter</b>	<b>3</b>
<b>2. Crane technology</b>	
2.1. Details of crane technology	3
2.2. Supporting base and working radius	3
2.3. Installing the lattice tower crane	4
2.4. Assembling the jib	4
<b>3. Access roads</b>	
3.1. Minimum requirements of access roads	4
3.2. Example of access road construction	5
3.3. Transport structure clearance	5
3.4. Access road bearing capacity	6
3.5. Basic principles of access road construction	6
<b>4. Radii of curves</b>	
4.1. Minimum requirements of intersections and curves	7
4.2. Radius of curve < 90 degrees	8
4.3. Road performance of vehicles in curves	8
<b>5. Transport and logistics</b>	
5.1. Basic principles of transport	9
5.2. Overview of transport vehicles	9
<b>6. Crane platforms</b>	
6.1. Minimum requirements of crane platforms	11
6.2. Standard crane platform	12

**Document information:**

Author/date:	Heiko Krey/10.05.06	Translator/date:	-
Department:	Project Management	Revisor/date:	-
Approved/date:	Gunda Hinderlich/18.07.07	Reference:	PM-CW-SP023-E82-77m Zuwegung und Kranstellfläche-Rev005ger-eng

## 1. Assembling the tower and wind energy converter

The tower and wind energy converter are installed in two stages (work steps):

### Step 1

Bolting the tower flanges to assemble the supplied tower sections. The 77m steel tower consists of four tower sections.

### Step 2

Preassembly of the supplied converter components and subsequent assembly of the wind energy converter.

## 2. Crane technology

### 2.1. Details of crane technology

The following crane technology is required for the work steps described above:

	<b>77m steel tower</b>
Crane type	800t lattice tower crane
Length/basic unit	20 m
Width/basic unit	3 m
Track width	3 m
Supporting base	13 m x 13 m
Working radius	28 m

### 2.2. Supporting base and working radius

The **supporting base** describes the distance between the four support cylinders arranged in a square (in metres).

The **working radius** is the minimum distance between the crane hook and the crane's live ring. Example: With a working radius of 28 m, the distance from the live ring to the centre of the foundation would be at least 28 m (see 6.2.).

<b>Document information:</b>		
Author/date:	Heiko Krey/10.05.06	Translator/date: -
Department:	Project Management	Revisor/date: -
Approved/date:	Gunda Hinderlich/18.07.07	Reference: PM-CW-SP023-E82-77m Zuwegung und Kranstellfläche-Rev005ger-eng

### 2.3. Installing the lattice tower crane

The following work steps need to be performed:

- Drive crane into position
- Align the crane with the centre of the WEC (taking into account the working radius)
- Use approx. 20 trucks to transport the crane accessories to the crane
- Support the crane on the crane platform using load distribution plates and
- Assemble jib

### 2.4. Assembling the jib

The individual jib (lattice tower) components should be assembled across a span of 95 m with the aid of an auxiliary crane. It should then be installed. During this process, the auxiliary crane must be positioned to the side of the jib of the main crane.

In order to facilitate consecutive assembly of the individual jib components, a stable roadway will be required for the auxiliary crane to travel along. You are advised to make use of the existing access road for the wind energy converter. If the existing access road is not suitable, a temporary roadway has to be constructed for the purpose of assembling the jib; this roadway has to be agreed with the competent ENERCON Project Manager on a case-by-case basis.

## 3. Access roads

Any roadways, bridges or access roads have to be able to withstand the transportation of heavy loads up to a maximum axle load of 12t and a maximum overall weight of 120t. Access has to be kept clear at all times. The responsible ENERCON Project Manager has to be informed of any failure to meet these requirements.

### 3.1. Minimum requirements of access roads

Useful width of carriageway	4 m
Clearance width	5.5 m
Clearance height	4.6 m
Radius of curve, external	28 m
Incline with loose surface	7%
Incline with fixed surface (paved)	12%
Ground clearance of transport vehicles	0.15 m

<b>Document information:</b>		
Author/date:	Heiko Krey/10.05.06	Translator/date: -
Department:	Project Management	Revisor/date: -
Approved/date:	Gunda Hinderlich/18.07.07	Reference: PM-CW-SP023-E82-77m Zuwegung und Kranstellfläche-Rev005ger-eng

### 3.2. Example of access road construction

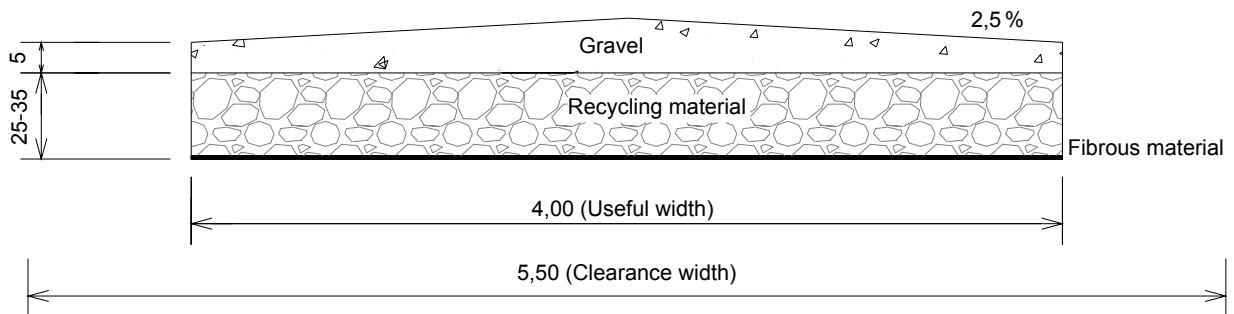

#### Caution:

The structure illustrated above is merely an example of average bearing soil. If the subsoil is soft (boggy soil, etc.), it may be necessary to use more backfill, install a geogrid and make use of gravel. ENERCON has always to be consulted prior to any construction work.

### 3.3. Transport structure clearance

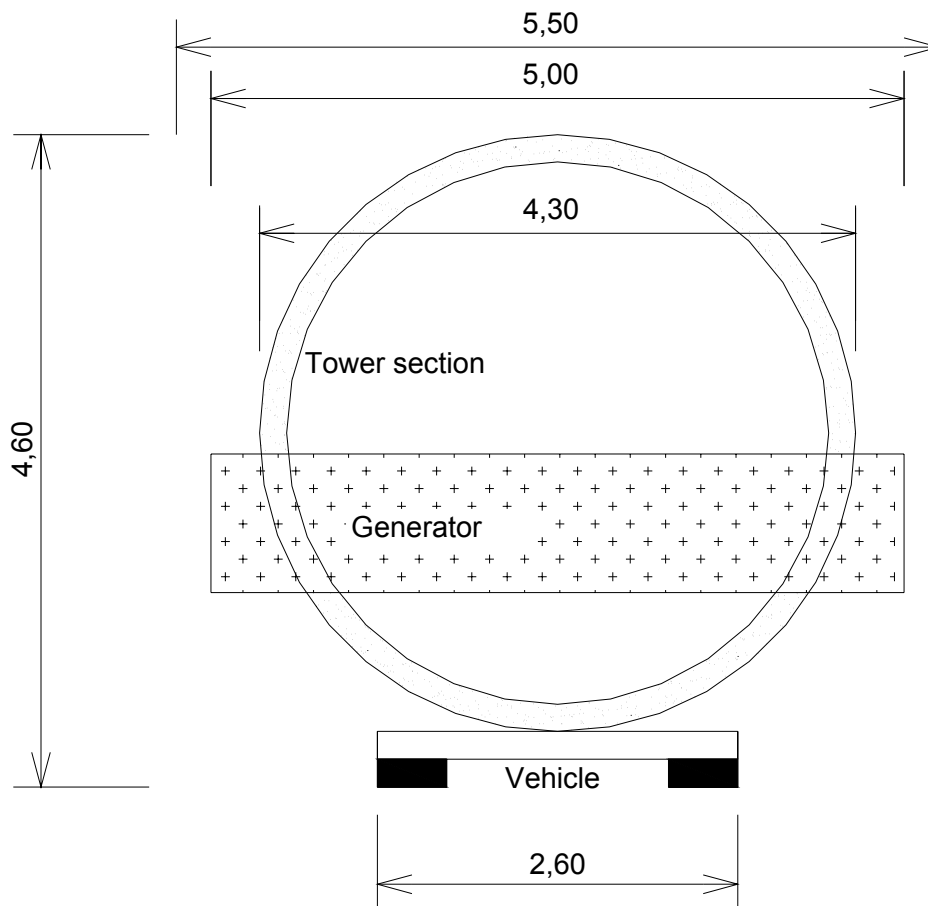

#### Document information:

Author/date:	Heiko Krey/10.05.06	Translator/date:	-
Department:	Project Management	Revisor/date:	-
Approved/date:	Gunda Hinderlich/18.07.07	Reference:	PM-CW-SP023-E82-77m Zuwegung und Kranstellfläche-Rev005ger-eng

### 3.4 Access road bearing capacity

In the case of cohesive soils, the use of a geotextile or geogrid is recommended, as this makes for better distribution of the load across the access road's subgrade. It will also increase the access road's service life and durability.

During construction, plate load bearing tests should be carried out to ensure that the necessary bearing capacity is achieved.

#### Data for soil experts:

Subsoil	$E_{v2} \geq 45 \text{ MN/m}^2$
Base course	$E_{v2} \geq 100 \text{ MN/m}^2$
Maximum axle load of transport vehicles	10t
Maximum axle load of crane	12t
Maximum vehicle weight	120t

### 3.5. Basic principles of access road construction

- Useful carriageway width of 4 m
- Able to withstand an axle load of up to 12t
- Able to withstand an overall weight of up to 120t
- Carriageway width of 5.5 m on curves
- No obstacles on inside/outside of curves
- Clearance width of 5 m
- Clearance height of 4.6 m
- Checking of bridge bearing capacity
- Checking of outlets and pipework
- Checking of distances from graves, hollows and watercourses
- Checking of distances from high voltage/electrical/telephone cables and
- Inspection of inclines

**Document information:**

Author/date:	Heiko Krey/10.05.06	Translator/date:	-
Department:	Project Management	Revisor/date:	-
Approved/date:	Gunda Hinderlich/18.07.07	Reference:	PM-CW-SP023-E82-77m Zuwegung und Kranstellfläche-Rev005ger-eng

## 4. Radii of curves

### 4.1. Minimum requirements of intersections and curves

In contrast to intersections, areas involving curves do not require the same degree of reinforcement, as the squinch does not need to be constructed.

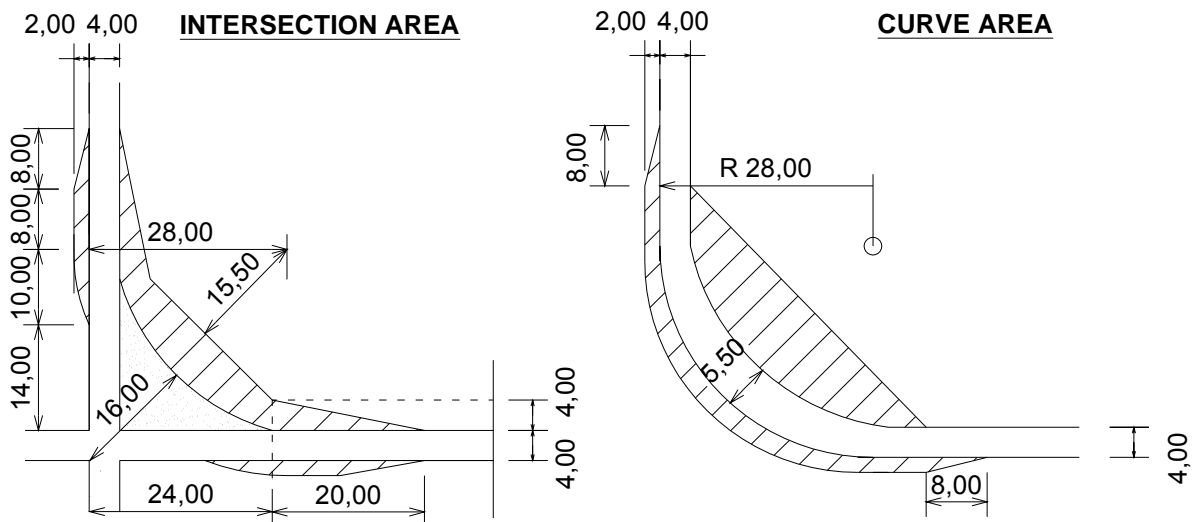

#### Intersections

The construction method for intersection areas as illustrated above should be used for existing intersections. The stippled area must be stable, or it will need to be reinforced.

The hatched areas have to be free of obstacles, as the load that is being transported may protrude into these areas (for example, rotor blades may protrude from the rear of the vehicle by 7 m during transport).

#### Curves

The construction method for curve areas as illustrated above should be used for new access roads within the context of any curves.

The hatched areas have to be free of obstacles, as the load that is being transported may protrude into these areas.

<b>Document information:</b>		
Author/date:	Heiko Krey/10.05.06	Translator/date: -
Department:	Project Management	Revisor/date: -
Approved/date:	Gunda Hinderlich/18.07.07	Reference: PM-CW-SP023-E82-77m Zuwegung und Kranstellfläche-Rev005ger-eng

#### 4.2. Radius of curve < 90 degrees

If the angle of the curve under construction is < 90 degrees, the curve moves outwards and the area associated with the necessary carriageway width of 5.5 m has to be enlarged accordingly (see marking). The load again protrudes into the inside and outside areas of the curve (see 4.1).

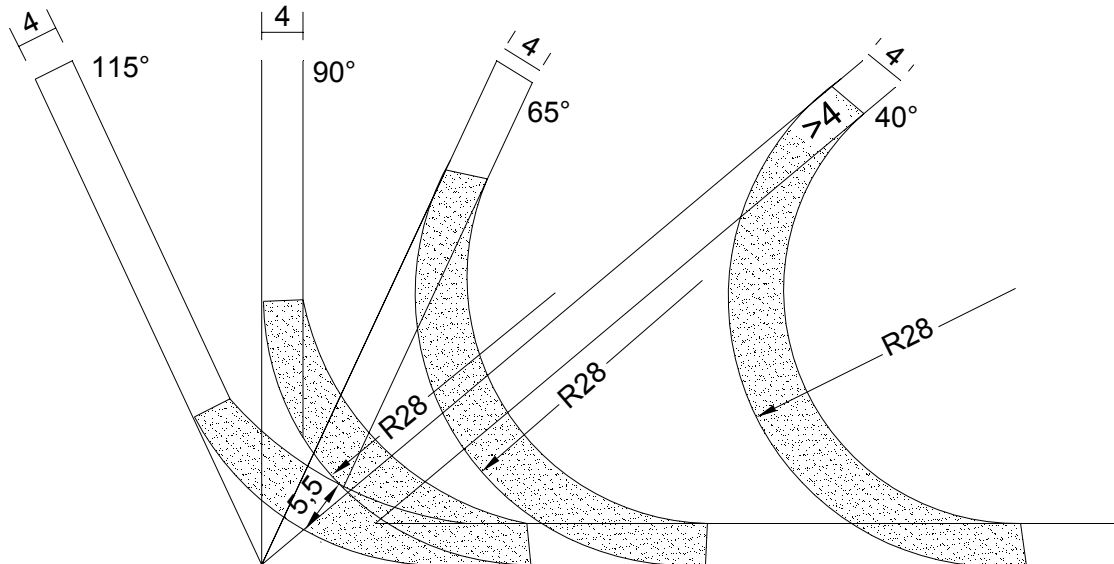

#### 4.3. Road performance of vehicles in curves

The figure below illustrates the movement of blades as they are transported round a curve.

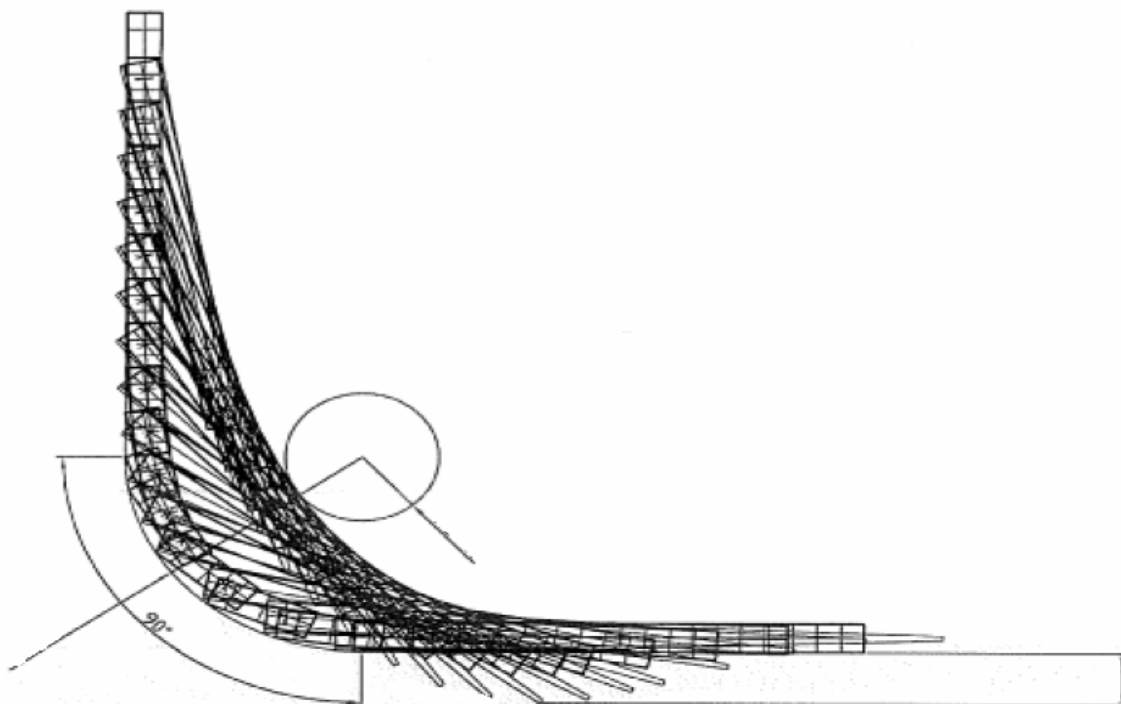
**Document information:**

Author/date:	Heiko Krey/10.05.06	Translator/date:	-
Department:	Project Management	Revisor/date:	-
Approved/date:	Gunda Hinderlich/18.07.07	Reference:	PM-CW-SP023-E82-77m Zuwegung und Kranstellfläche-Rev005ger-eng

## 5. Transport and logistics

### 5.1. Basic principles of transport

It is a basic principle that transport vehicles should not exceed the maximum axle load of 10t. Thus, a transport vehicle with an actual overall weight of 100t has to have at least 10 axles.

The following vehicles are used on ENERCON construction sites:

- Lowloader trailers
- Drop base vehicles
- Semi trailers and
- Adapter vehicles

The vehicles vary to some extent in terms of length and width and can be shortened (pushed in) by several metres once they have been unloaded.

### 5.2. Overview of transport vehicles

Semi trailer, steel section

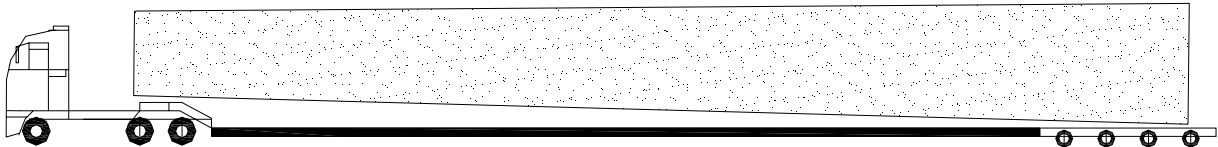

Telescopic semi, machine house components

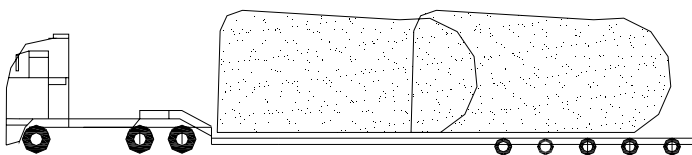

<b>Document information:</b>		
Author/date:	Heiko Krey/10.05.06	Translator/date: -
Department:	Project Management	Revisor/date: -
Approved/date:	Gunda Hinderlich/18.07.07	Reference: PM-CW-SP023-E82-77m Zuwegung und Kranstellfläche-Rev005ger-eng

Flatbed trailer, hub

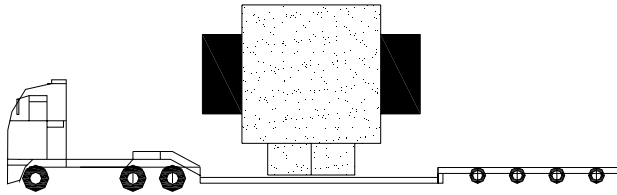

8-axled semi, generator

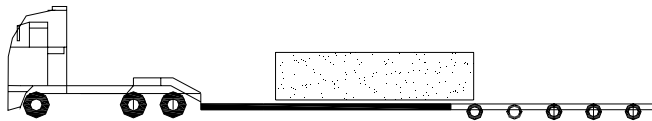

Semi trailer, rotor blade

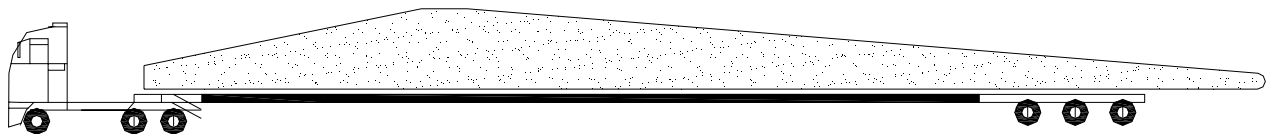

**Document information:**

Author/date:	Heiko Krey/10.05.06	Translator/date:	-
Department:	Project Management	Revisor/date:	-
Approved/date:	Gunda Hinderlich/18.07.07	Reference:	PM-CW-SP023-E82-77m Zuwegung und Kranstellfläche- Rev005ger-eng

## 6. Crane platforms

### 6.1. Minimum requirements of crane platforms

The crane platform is the key to ensuring that everything runs smoothly and safely during the construction phase.

It should take the form of a coarse, level surface with a top surface made from recycled materials or mixed minerals with a grain size of 0 – 32 mm.

The crane platform should be located above ground level to ensure that surface water is properly dispersed.

During construction, plate load bearing tests should be carried out to ensure that the necessary bearing capacity is achieved.

Any cranes used have a maximum support pressure of 200t and are supported on the crane platform by means of load distribution plates. Pressures of up to 18.5t/m<sup>2</sup> may act on the platform as a result of this and the maximum surface pressure is therefore **185 kN/m<sup>2</sup>**.

The dimensions of the crane platform should be calculated so that all the work necessary for installing the wind energy converter (including tower) can be carried out in the optimum manner. The example given in 6.2 provides a basic standard. This can be adapted to local conditions in consultation with the competent ENERCON Project Manager.

The soft, levelled assembly area can be located either to the left or to the right of the crane platform.

To ensure that any components inside the tower can subsequently be replaced and to protect the wind energy converter against ingress of dirt, a 6 m wide and stable access road has to be constructed between the crane platform and the tower once the foundation has been backfilled.

During foundation construction, the crane platform also serves as a storage area for material (e.g. reinforced steel) and machinery.

Any excess earth excavated during the construction phase should always be stored behind the foundation (see 6.2).

<b>Document information:</b>		
Author/date:	Heiko Krey/10.05.06	Translator/date: -
Department:	Project Management	Revisor/date: -
Approved/date:	Gunda Hinderlich/18.07.07	Reference: PM-CW-SP023-E82-77m Zuwegung und Kranstellfläche-Rev005ger-eng

**6.2. Standard crane platform**

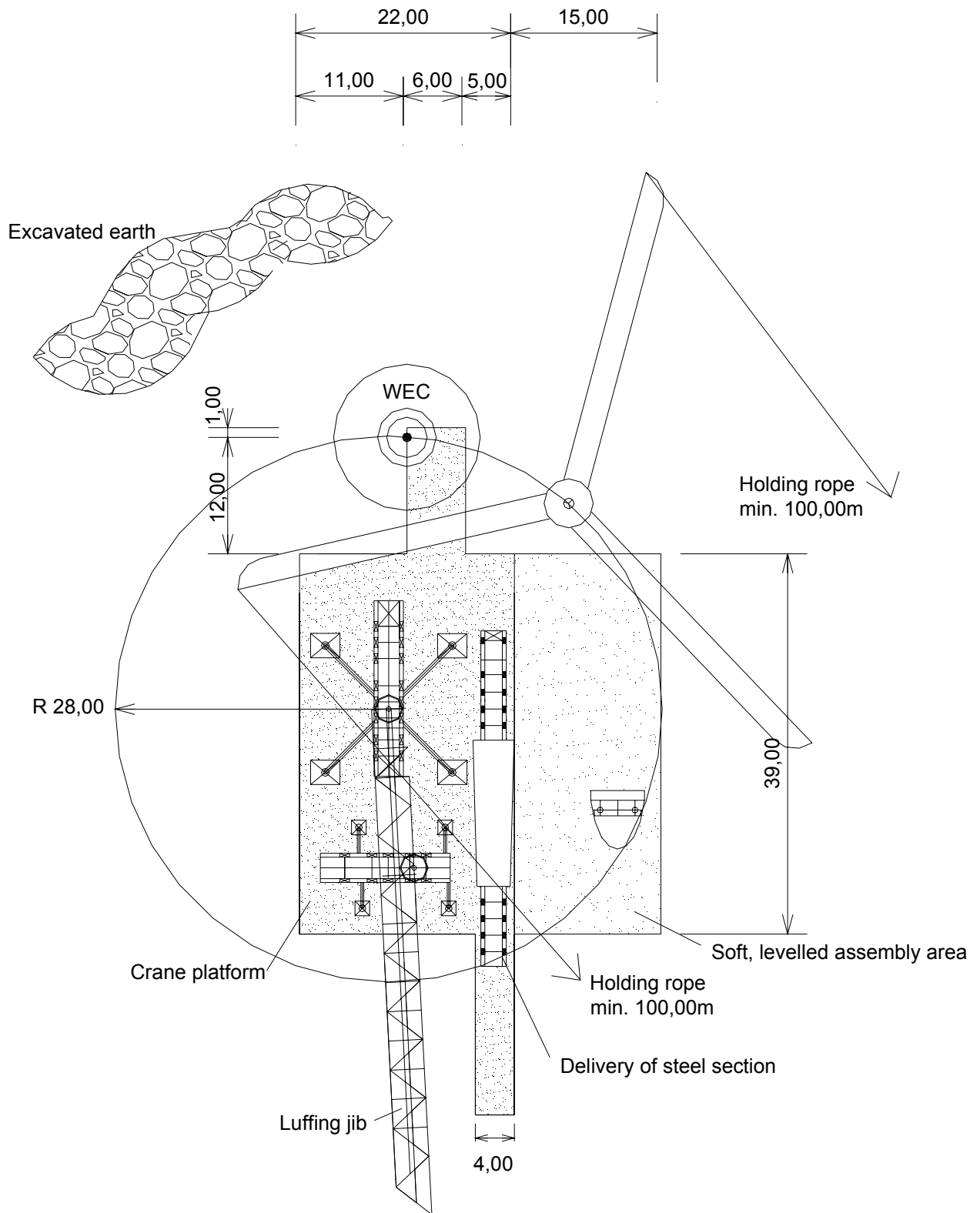

**Document information:**

Author/date:	Heiko Krey/10.05.06	Translator/date:	-
Department:	Project Management	Revisor/date:	-
Approved/date:	Gunda Hinderlich/18.07.07	Reference:	PM-CW-SP023-E82-77m Zuwegung und Kranstellfläche-Rev005ger-eng